



RE

**"Isabella" Gear-box
Dismantling (320 50)
and
Assembly (320 60)**

Bremen, 24.11.1959

Technical Data

Gear-box : BORGWARD fully synchromesh 4-speed
Oil Capacity: 1 3/4 pint (1 litre) SAE 90 Gear-oil

Pinion Layout

(Schema)

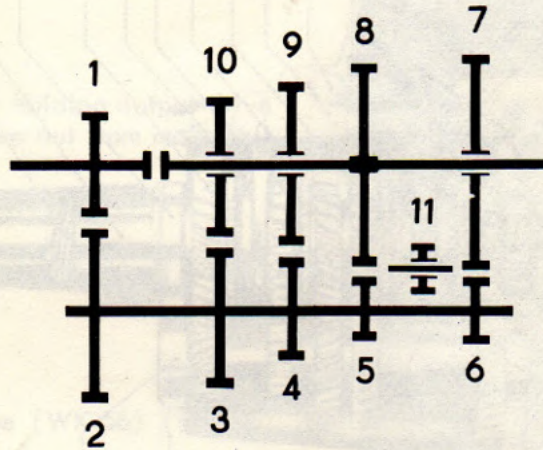

Car Gear-box			
Isabella, TS, TS de Luxe, Coupé, Combi			
Gears	Ratio	The following are coupled:	
		Pinions	Teeth
1st Gear	3.86 : 1	$\frac{1 7}{2 6}$	$\frac{21 38}{32 15}$
2nd Gear	2.15 : 1	$\frac{1 9}{2 4}$	$\frac{21 31}{32 22}$
3rd Gear	1.36 : 1	$\frac{1 10}{2 3}$	$\frac{21 25}{32 28}$
4th Gear	1 : 1	direct drive	
Reverse	4.06 : 1	$\frac{1 8}{2 5}^{11}$	$\frac{21 32}{32 12}^{19}$
Speedometer Drive	2 : 1		5 : 10

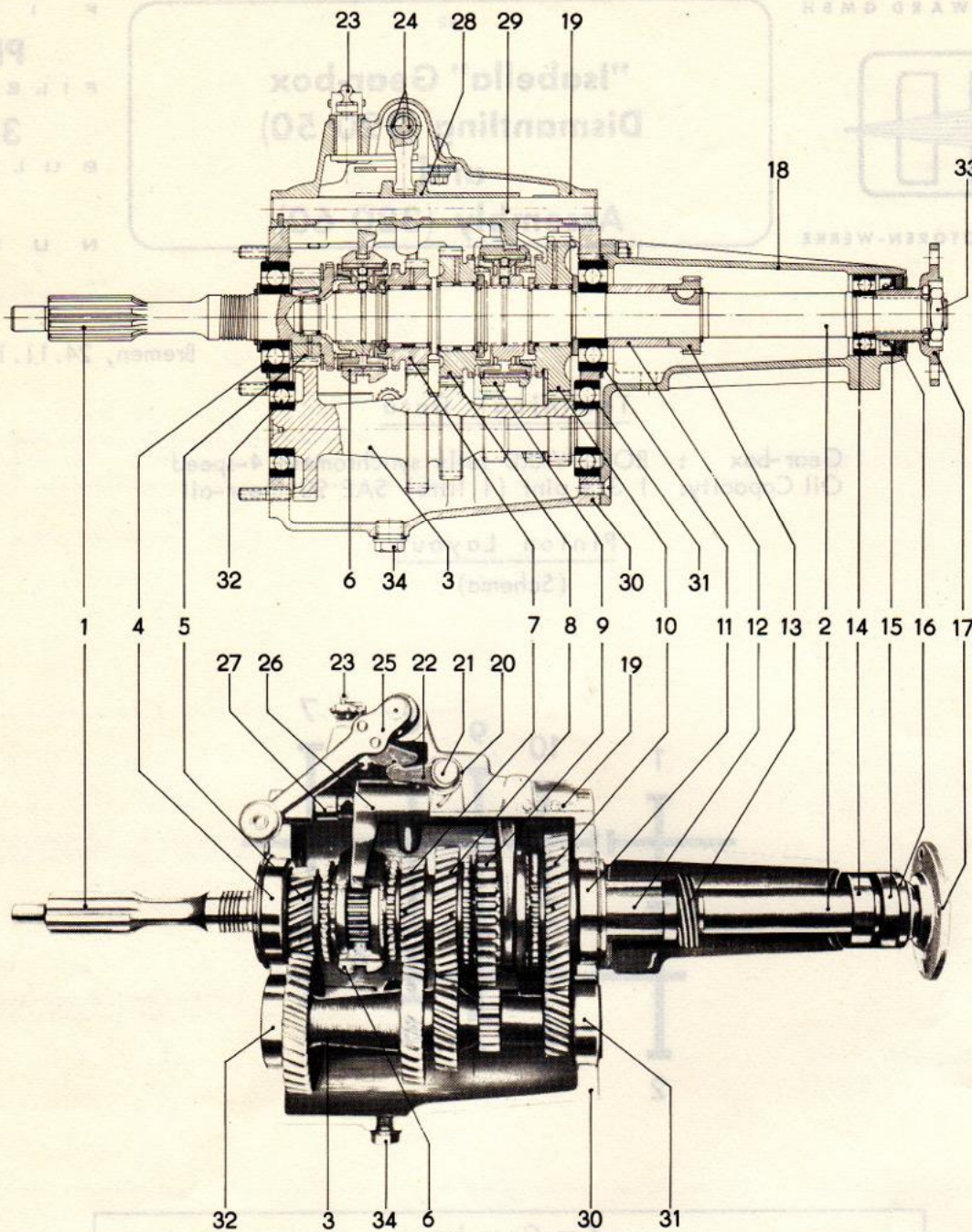

- | | |
|---|--|
| 1. Input shaft | 18. Speedometer or tail housing |
| 2. Main shaft | 19. Selector head |
| 3. Layshaft | 20. Torsion spring |
| 4. Input shaft ball-race 6306 "NC 3" | 21. Ratchet spindle |
| 5. Input shaft constant-mesh pinion | 22. Ratchet |
| 6. Selector slide and sleeve for 3rd and 4th gear | 23. Upper selector lever |
| 7. 3rd gear helical pinion | 24. Selector spindle with inner selector lever |
| 8. 2nd gear helical pinion | 25. Outer gear-change lever |
| 9. Reverse gear selector (with slide) | 26. 3rd and 4th gear selector fork |
| 10. 1st gear helical pinion | 27. Selector-fork spindle for 3rd and 4th gear |
| 11. Mainshaft ball-race 6306 "NC 3" | 28. 1st and 2nd gear selector fork |
| 12. Distance piece | 29. Selector-fork spindle for 1st and 2nd gear |
| 13. Speedometer drive skew-gear | 30. Gear-box casing |
| 14. Mainshaft tail bearing 6205 "C 2" | 31./32. Layshaft ball-races |
| 15. Circular packing ring | 33. Hexagonal nut |
| 16. Felt washer holder with felt ring and washer | 34. Oil drain plug |
| 17. Output drive flange | |

Dismantling the Gear-box (320 50)

Initial Preparations:-

Drain oil from gear-box, removing drain and filler plugs. Remove clutch housing from gear-box casing.

1. Fit gear-box assembly jig (BW 11) firmly in vice and attach gear-box to it (Fig.1).
2. Put outer gearchange lever on selector head in neutral
3. Unscrew cover nuts and loosen cover with a few light taps with a hide-headed hammer and remove.
4. Bend back tab washer holding output drive flange nut and unscrew nut from mainshaft (WK 112) (Fig.2).
5. Mark drive flange and mainshaft with a centre punch (Fig.3).

Draw off drive flange (WK 56) (Fig.4).

6. Undo nuts and lower countersunk screw from tailshaft housing. Loosen casing with a few light taps of hide hammer and remove (Fig.5).

Extract packing ring, felt washer with holder and washer.

(It does not matter if the packing ring is damaged in the process, as a new one is fitted on re-assembly).

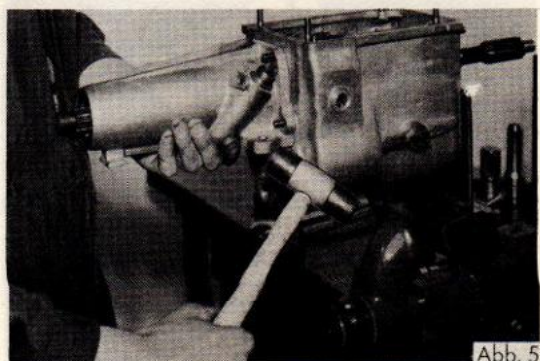
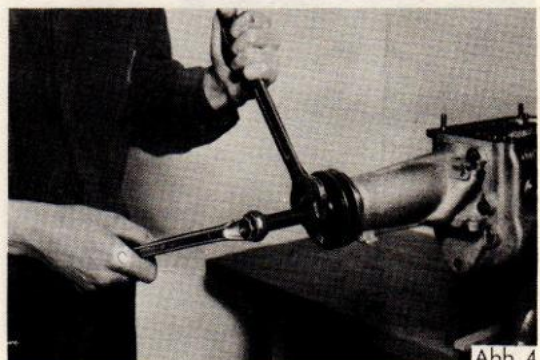
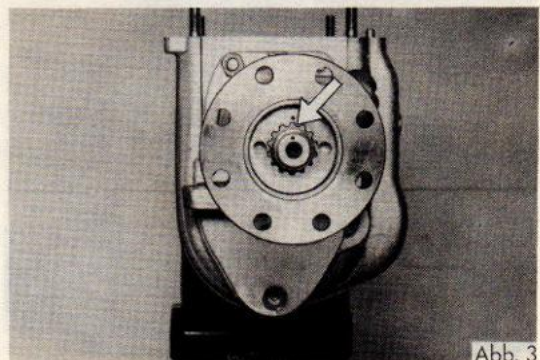
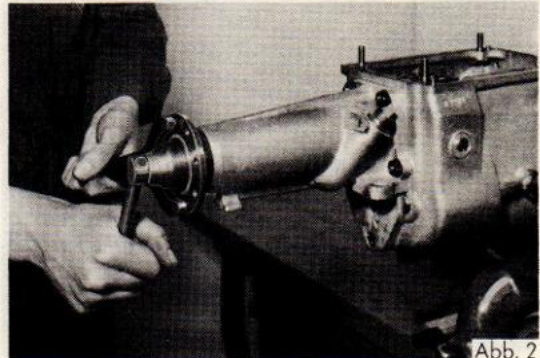
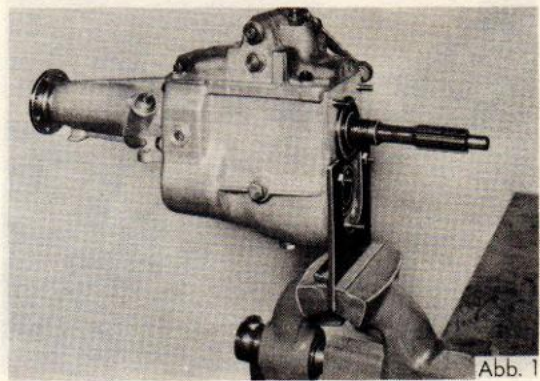



Abb. 6

7. Draw tailshaft bearing from mainshaft (Use standard commercial type drawer) (Fig.6).

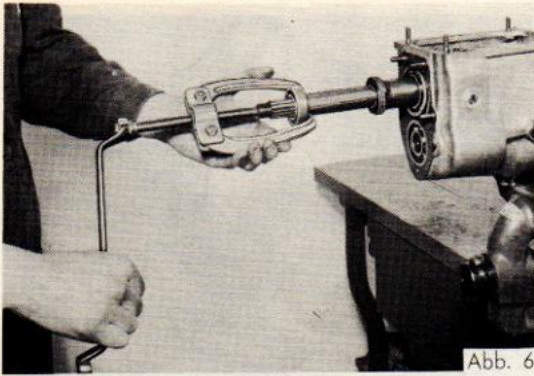

Abb. 7

8. Remove speedometer drive skew-gear circlip and ease skew-gear off shaft with a few light taps from hide-hammer. Remove spring washer from shaft and take off distance piece.

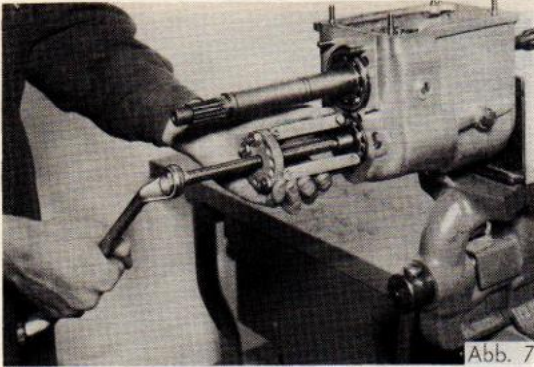

Abb. 8

9. Extract ball-races from both ends of layshaft (use standard commercial type drawer) (Fig.7).

Let layshaft pinions rest on bottom of casing.

10. Remove input shaft and pinion from gear-box casing, using hardwood punch (Fig.8), then remove toothed check-ring and needle cage.

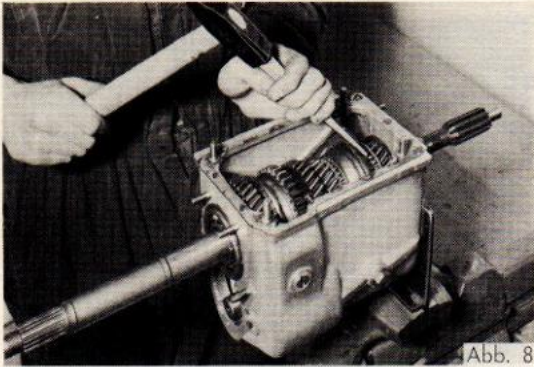

Abb. 9

11. Remove circlip from mainshaft ball-race using pin-nosed pliers and screwdriver. Draw race from mainshaft and gear-box casing (WK 145).

12. Remove mainshaft from gear-box, by lifting it by selector slide upwards and outwards towards the input side (Fig.9).

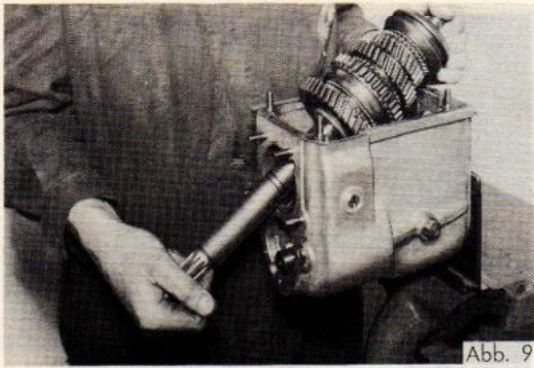

Abb. 10

13. Lift layshaft out of gear-box.

14. Drive out reverse gear spindle (Fig.10) and remove reverse gear pinion and thrust washer.

15. Remove reverse gear pinion double lever with fulchrum plate from gear-box.

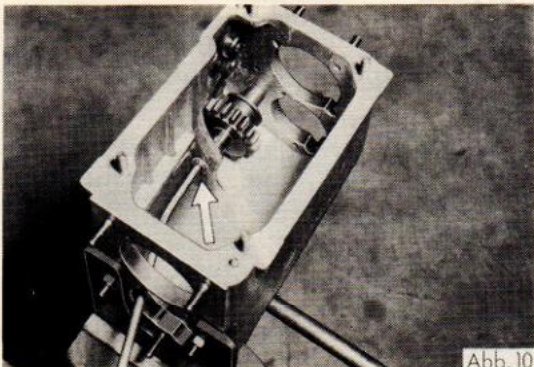
Dismantling Mainshaft

16. Remove selector slide with sliding sleeve for 3rd and 4th gear from mainshaft, first removing toothed check-ring.
17. Place 1st gear pinion with mainshaft over vice jaws and drive off mainshaft with rear thrust washer (Fig.11).
18. Remove toothed check-ring, needle cage and front thrust washer for 1st gear from mainshaft.
19. Remove reverse gear pinion (sliding sleeve) with selector slide from mainshaft, then toothed check-ring (Fig.12).
20. Remove circlip from in front of 2nd gear pinion (Fig.13) and then remove 2nd gear pinion with thrust washer from mainshaft. Then lift off needle cage.
21. Remove circlip from in front of 3rd gear pinion. Remove pinion with thrust washer from mainshaft; lift off needle cage.
22. Separate 3rd and 4th gear sliding sleeve from selector slide carefully.

Important! This releases selector balls and springs.

23. Remove reverse gear pinion from selector slide and extract balls and springs from interior.

Dismantling Input Shaft

24. Remove circlip from in front of input shaft race.
25. Remove spacer and washer from input shaft.
26. Press race off input shaft (Fig.14). Remove oil slinger.
27. Press constant-mesh pinion off shaft. (The oil slinger will be damaged by this operation and must not be re-used) (Fig.15).



Abb.11



Abb.12



Abb.13

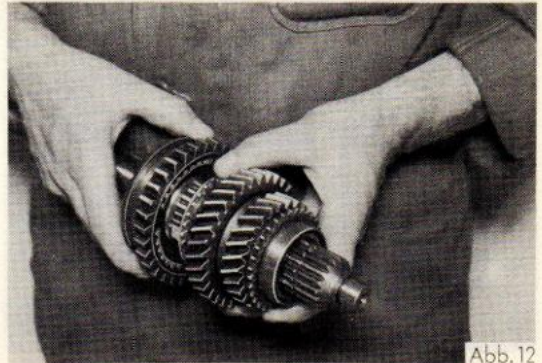

Abb.14



Abb.15

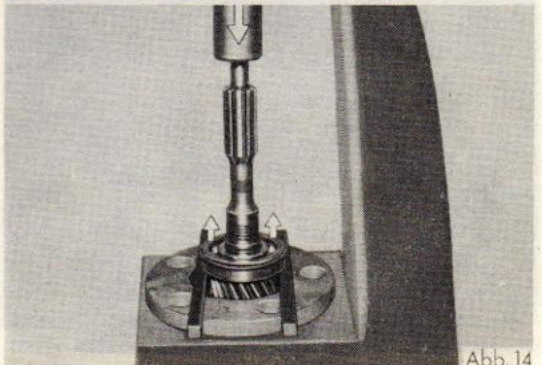

Abb. 16

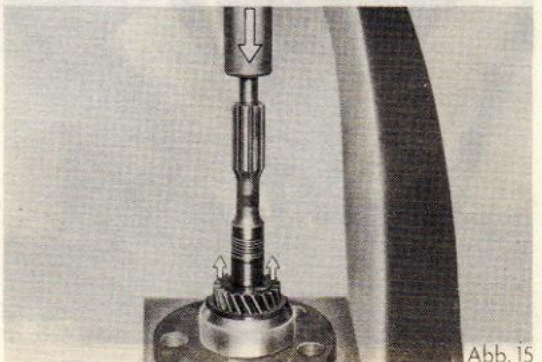

Abb. 17

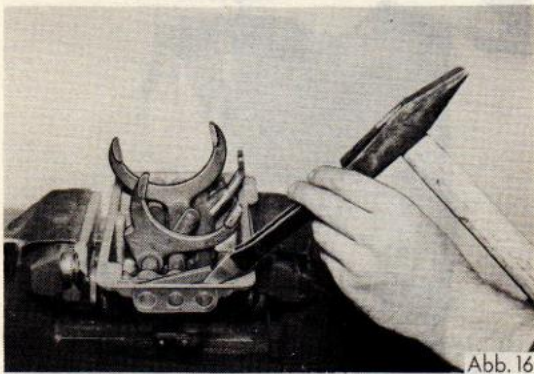

Abb. 18

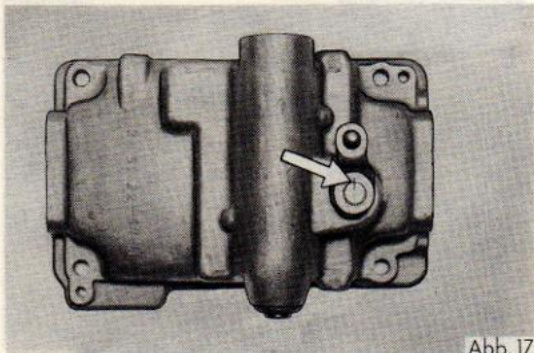

Abb. 19



Abb. 20

Dismantling Selector Head

28. Hold cover casting in vice (using protective clamps). Drive out selector spindle locking plate from cover with cross-cut chisel (Fig.16).
29. Drive selector spindles out of head with a suitable drift. Remove selector forks from head and springs and balls from forks.
30. Unscrew sliding lock plate screws complete with distance pieces.
31. Remove circlip and washer from gear-change lever spindle. Draw spindle sideways from head, removing spring, washer, selector finger and distance piece from inside.
32. Unscrew nut from ratchet spindle. Withdraw ratchet spindle complete with ratchet and torsion spring sideways from head.
33. Mark the relative positions of the two selector levers with a chisel cut (Fig.17). Drive out pin from outer selector lever with a punch (Fig.18). Separate inner selector lever from outer by driving out.
34. After the gear-box has been completely dismantled, all parts should be carefully cleaned and inspected for suitability for re-use.

Gear-box Assembly (320 60)

Mainshaft Assembly

1. Smear 3rd gear needle cage with oil and fit to mainshaft.
2. Fit 3rd gear pinion on mainshaft with synchronizing cones towards the front (input) end of gear-box (Fig.19).
3. Fit thrust washer with oil groove towards 3rd gear pinion on mainshaft and secure with circlip.
4. Measure clearance between 3rd gear pinion and mainshaft thrust collar (.004 - .006" or 0.10 - 0.15 m/m) (Fig.20). If clearance is not within prescribed limits, thrust washer must be changed.

- Moisten 2nd gear pinion needle cage with oil and fit to mainshaft. Then 2nd gear pinion with cone towards output end (Fig. 21).



Abb. 21

- Fit thrust washer with oil groove towards 2nd gear pinion and secure with circlip. Check clearance between 2nd gear pinion and mainshaft thrust washer (.004 - .006" or 0.10 - 0.15 m/m). If clearance varies outside these limits, the thrust washer must be re-newed (Fig.22).



Abb. 22

- Place toothed check ring on cone of 2nd gear pinion. Ascertain clearance between outer face of engaging teeth of 2nd gear pinion and the edge of the toothed check ring (Fig.23). If the clearance is less than .039" (1 m/m), the check ring must be replaced.



Abb. 23

- Fit balls and springs to reverse gear pinion sliding selector (fit long springs in stop-holes with ball on top and short springs with ball at each end in through holes). Insert selector slide into reverse gear pinion (Fig.24).

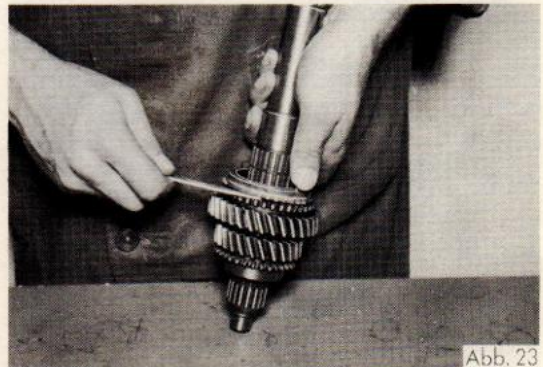

Abb. 24

- Fit selector slide and reverse gear pinion on mainshaft with selector fork groove towards the output (rear) end. The projections of the toothed check ring must engage with the slots in the selector slide (Fig.25).



Abb. 25



Abb. 26



Abb. 27

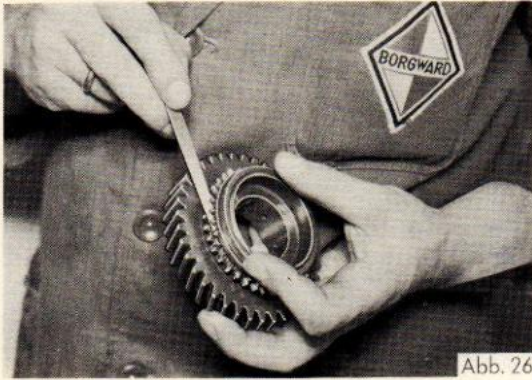

Abb. 28

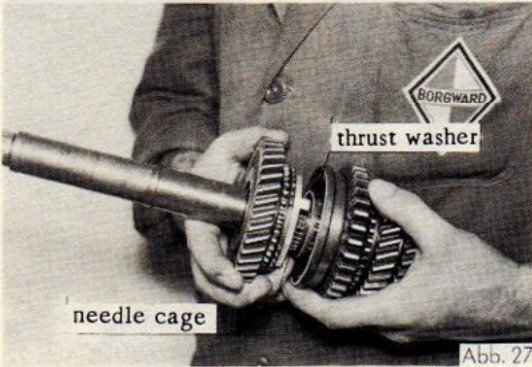

Abb. 29

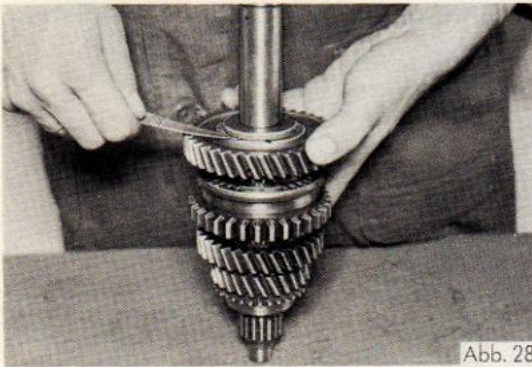

Abb. 30

10. Place 1st gear pinion thrust washer on mainshaft with groove upwards. Smear 1st gear pinion needle cage with oil and place on mainshaft (see Fig.27).

11. Fit toothed check ring on cone of 1st gear pinion and check clearance between outer edge of pinion engaging teeth and inner face of check ring. If it is less than .039" (1 m/m), fit new toothed check ring.

12. Fit 1st gear pinion with toothed check ring on mainshaft. The projections on check ring must engage with slots in selector slide (Fig.27).

13. Press 1st gear pinion thrust washer on to mainshaft with chamfer upwards (using suitable piece of tube). Measure clearance between thrust washer and 1st gear pinion (.004 - .006" or 0.10 - 0.15 m/m) (Fig. 28). If it is outside the prescribed limits, the thrust washer must be replaced.

14. Insert balls and springs in 3rd and 4th gear selector slide. Insert slide in sleeve (Fig. 29).

Important! Long springs in stop holes, each with one ball. Short springs with ball at each end in through holes.

15. Fit toothed check ring on cone of 3rd gear pinion. Check clearance between outer edge of engaging teeth and face of check ring as in Fig. 26 above. If clearance is more than .039" (1 m/m), re-new check ring.

16. Fit selector slide and sleeve on mainshaft with the broader side towards the output (rear) end (Fig.30).

Input Shaft Assembly

17. Fit input shaft fitting spring in input shaft and place washer on shaft.
18. Heat input shaft constant-mesh pinion up to c. 300° F (150° C) and press quickly on input shaft to prevent it cooling off too soon, using suitable piece of tube. Ensure that shoulder on pinion faces upwards. (Fig.31).
19. Place oil slinger ring on input shaft above pinion and press ball-race onto shaft with circlip upwards (Fig.32).
20. Place fitting washer with spacer in front of ball-race on input shaft. Secure fitting washer and spacer with circlip. Check clearance of spacer washer. It should only just be possible to turn it by hand (Fig.33). The clearance must be made up by fitting suitable shims. (Shims are available in .004" and .008" (0.1 and 0.2 m/m) thicknesses).

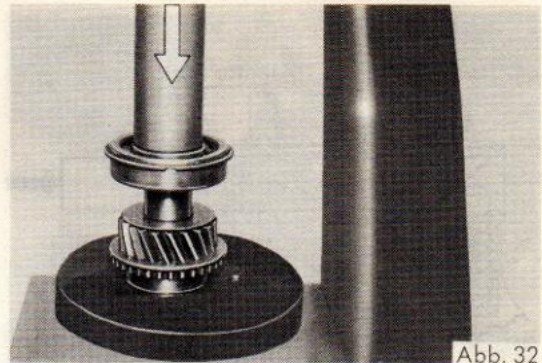
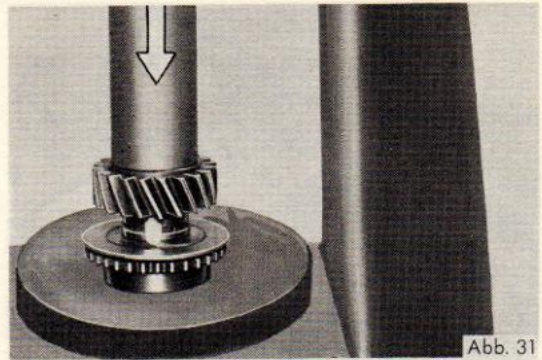

Selector Head Assembly

21. Fit outer selector lever to inner selector lever and secure with split taper pin. The relative positions of the two levers are already marked and this must be observed (Fig.34).
22. Fit torsion spring onto selector head. Insert ratchet spindle with ratchet and washer into head from outside. Screw nut with spring washer loosely onto spindle from inside.
23. Insert gearchange spindle complete with lever from outside into selector head and fit distance piece, selector finger, washer and spring onto spindle from inside head.



Important!

When fitting selector finger, ensure that it remains exactly perpendicular, with the ratchet outside engaged with the gearchange lever (Fig.35).



Abb. 36



Abb. 37

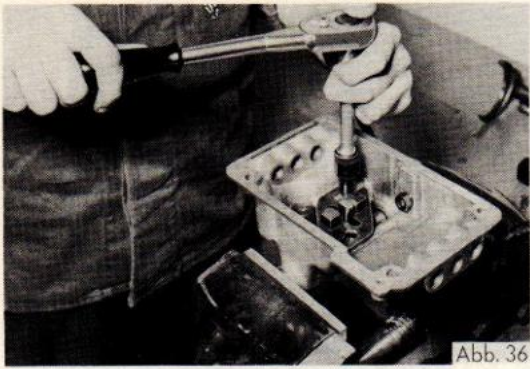

Abb. 38

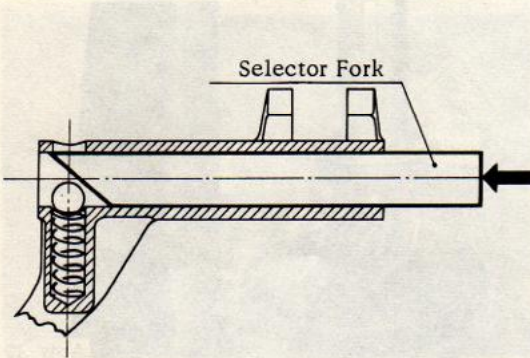

Abb. 39

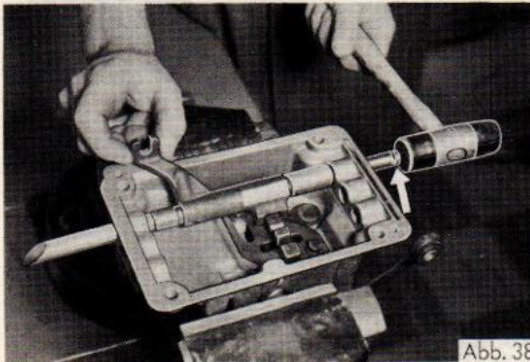

Abb. 40

24. Fit washer on selector finger spindle (outside head) and secure with circlip.

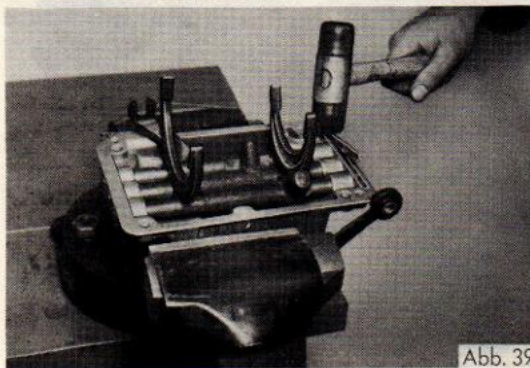
25. Fit sliding lock plate over selector finger. Insert screws with distance pieces and spring washers into head and tighten down (Fig.36).

(The sliding lock plate must move easily).

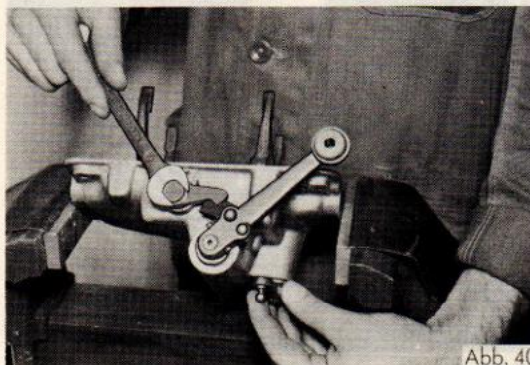
26. Fit reverse gear selector fork with spring and ball. Insert chamfered drift so that spring and ball are forced downwards (Fig.37).

27. Fit reverse gear selector spindle on the opposite side to the outer gearchange lever with distance pieces and selector fork and drive in with hide hammer. The long distance piece at the front when viewed from the direction of travel, the shorter piece to the rear.

Important!

When inserting selector spindles, ensure that the locking grooves face upwards (Fig.38).

28. Insert 1st and 2nd gear selector spindle into selector head and fit selector fork previously fitted with spring and ball.

29. Insert 3rd and 4th gear selector spindle into head and fit selector fork complete with spring and ball.

30. Insert selector spindle locking plate into selector head (Fig.39)

31. Adjust selector finger. To do this, the eccentric ratchet spindle is turned so that the selector finger is aligned exactly between the two blocks of the sliding lock plate (Fig.40). Hold the finger in this position by moving the lock plate sideways, so that it is exactly in the slots of the selector forks.

32. After adjusting, tighten nut on ratchet spindle and secure with centre punch (Fig.41).



Abb. 41

Gear-box Assembly

(Mainshaft, Input Shaft and Selector Head previously assembled).

33. Fit double lever with fulchrum plate and insert on bearing pin in gear-box casing.
34. Drive in reverse gear spindle, fitting reverse gear pinion so that the guide slot for the fulchrum plate faces the output end. Fit thrust washer on spindle and drive spindle to within the casing (Fig.42). Locate the spindle accurately as it is locked against turning by the tail housing (Fig.43).

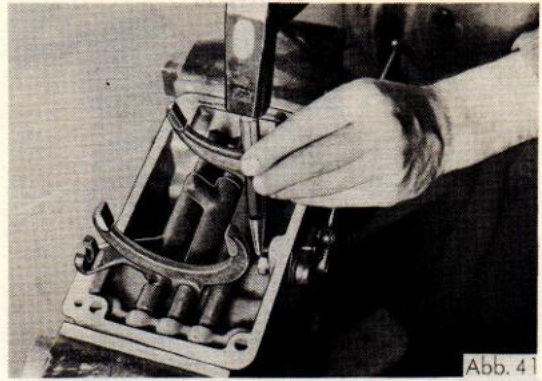

Abb. 42

(Reverse gear pinion play $.002'' \pm .0005''$ or $0.04 - 0.06$ m/m)

35. Place layshaft in bottom of gear-box casing.

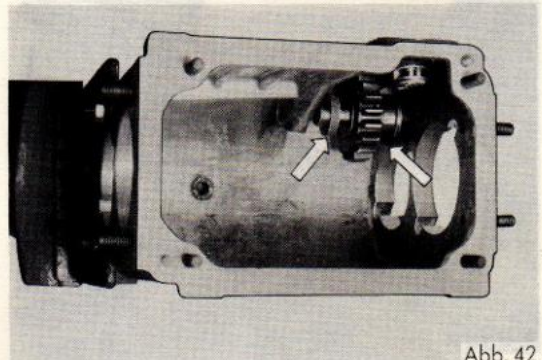

Abb. 43

36. Place toothed check ring on cone of input constant-mesh pinion. (If there is less than $.039''$ or 1 m/m clearance between the outer edge of the engaging teeth and face of check ring, then the latter must be replaced) (Fig.44).

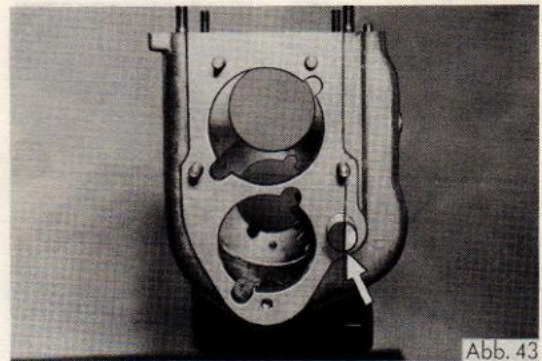

Abb. 44

37. Smear needle cage with oil and insert in input shaft aperture.

Disassembling input shaft

38. Before inserting mainshaft, the true running of the output drive flange should be checked. Fit ball-race and flange to mainshaft and tighten holding nut. Mount mainshaft between a pair of centres and check outer face of flange for truth.

(Permitted variation $.0005''$ or 0.015 m/m) (Fig.45).

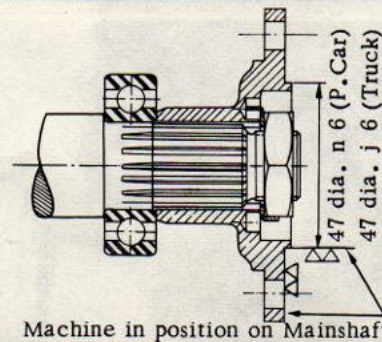

Machine in position on Mainshaft
Maximum permitted variation from true, $.0005''$ (0.015 m/m).

Abb. 45



Abb. 46



Abb. 47

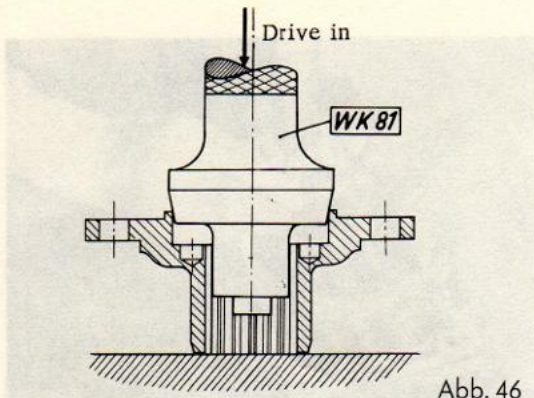

Abb. 48

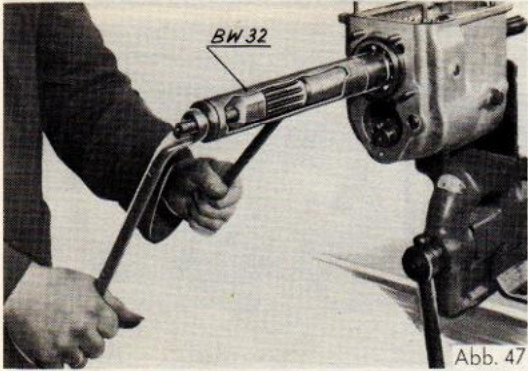

Abb. 49



Abb. 50

If this tolerance is exceeded, the flange must be dismantled again and fitted on mandrel WK 81 (Fig.46) and machined true with the shaft. The relative positioning of the flange on the shaft (male and female splines) must be marked afresh.

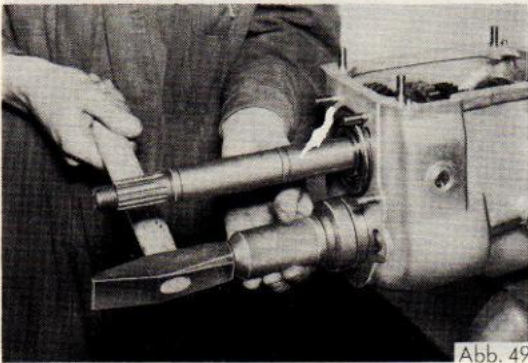
Should a new flange or mainshaft be fitted, the same procedure should be carried out.

39. Insert input and main shafts into the gear-box. The projections of the toothed check ring on the input shaft must mate with the recesses in the selector slide on the mainshaft.

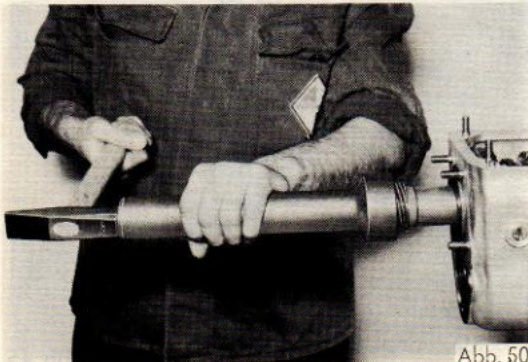
40. Press input shaft with ball-race into gear-box casing (using suitable piece of tube). Fit ball-race on mainshaft using assembly jig BW 32 fitted to mainshaft, press the race into gear-box casing. If need be, tap the bearing home with suitable piece of tube.

41. Locate layshaft at output end of gear-box with a drift or punch. Lift layshaft at input end with a punch and locate. Tap bearing home on layshaft journal with hide hammer (Fig.48).

Finally drive home bearing at output end with suitable tool (Fig.49).

42. Slide distance piece on mainshaft. Fit speedometer drive skew-gear spring washer on mainshaft.

43. Fit speedometer drive skew-gear to mainshaft with cone towards gear-box and secure with circlip (Fig.50).

Grease speedometer drive skew-gear.

44. Press tail bearing onto tail of mainshaft.
(Use suitable piece of tube) (Fig.51).



Abb. 51

45. Smear tail housing joint with jointing compound and stick to joint face.

46. Fit tail housing over mainshaft onto gear-box casing. Screw on nuts with shakeproof washers and tighten to a torque of 23 ft/lb (3.2 m/kg) (Fig.52). Insert countersunk screw and secure with centre-punch.

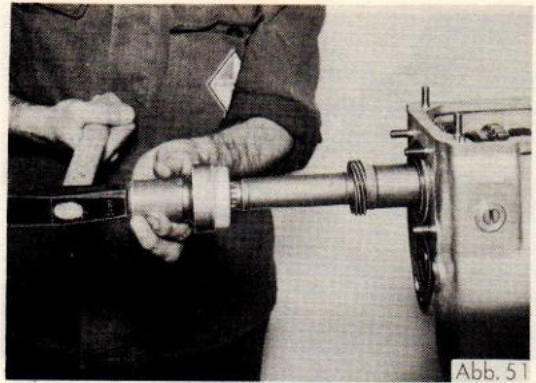

Abb. 52

47. Insert packing ring, washer and felt washer with holder together in tail housing. To press these in, a special assembly drift with a shoulder is used. The distance between the felt washer holder and the end face of the housing should be .039" (1 m/m).

Sectional Diagram Fig.53

Upper half without driving flange, but with drift BW 31.

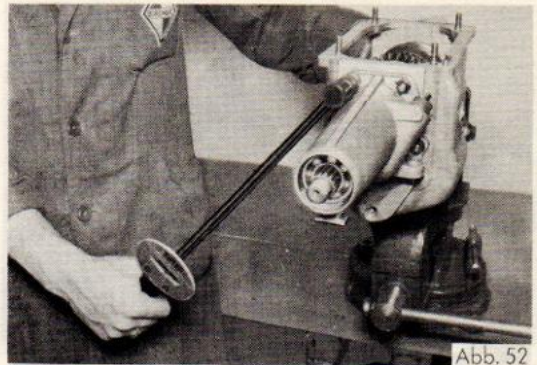
Lower half with driving flange complete!



Abb. 53

48. Fit driving flange in mainshaft in original position marked by centre-punch (Fig. 54). Fit tab washer, screw on nut, tighten and secure.

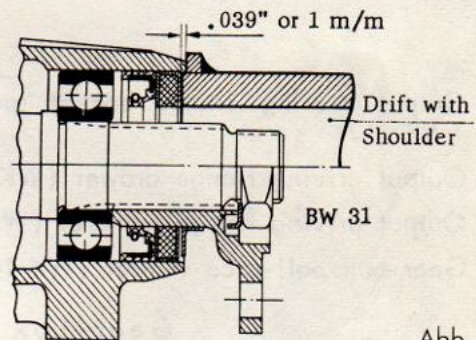

Abb. 54

49. Smear selector head joint with jointing compound and stick to gear-box casing. Fit selector head to gear-box, first sliding double lever to input end to ensure engagement of reverse gear selector fork in double lever (Fig.55).



Abb. 55

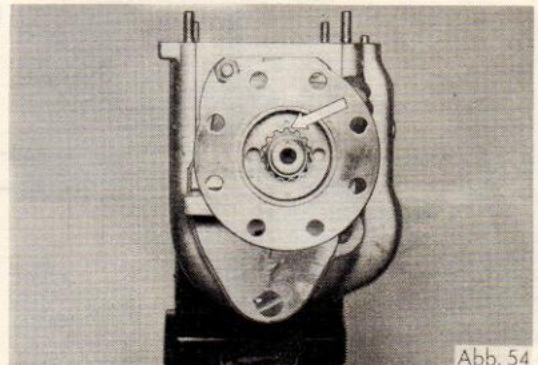

Abb. 56

50. Screw on selector head nuts with shake-proof washers and tighten to a torque of 22 ft/lb (3.0 m/kg) (Fig.56).

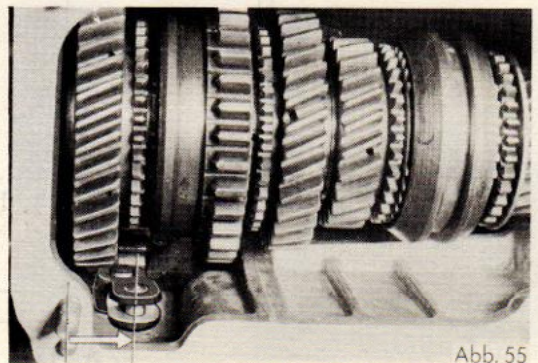

Abb. 57

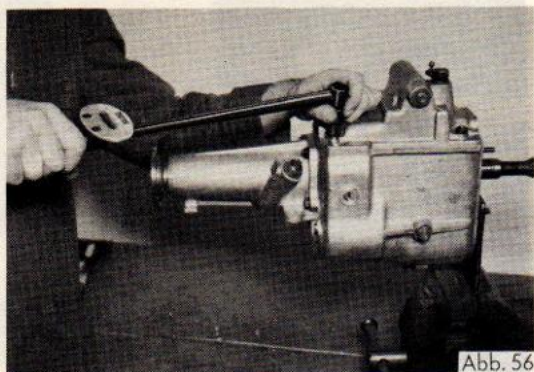
On final installation in vehicle only!

Detach gear-box from assembly jig, smear clutch housing joint with jointing compound and stick on clutch housing. Fit clutch housing to gear-box, screw on nuts with shakeproof washers and tighten to a torque of 22 ft/lb (3.0 m/kg) (see also Technical Circular PKW 1/32-37/2) (Fig.57).

Screw in oil filler and drain plugs and tighten.

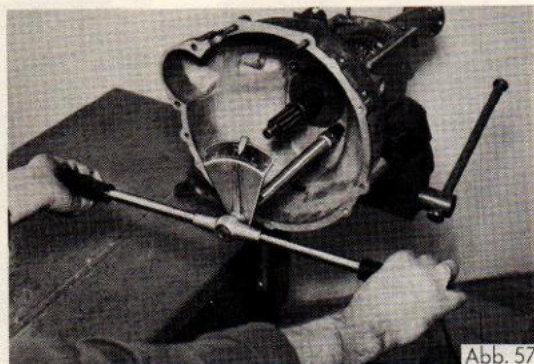
Fill with gear oil!

Special Tools

- | | |
|--|---|
| 1. Output driving flange socket spanner (WK 112) | 5. Layshaft bearing extractor (commercial type) |
| 2. Output driving flange drawer (WK 56) | 6. Ball-race extractor for mainshaft tail bearing (commercial type) |
| 3. Output driving flange mandrel (WK 81) | 7. 72 ft/lb (10 m/kg) torque wrench |
| 4. Gear-box ball-race drawer (WK 145) | |

Gear-box Assembly Jig BW 11

(Homemade)

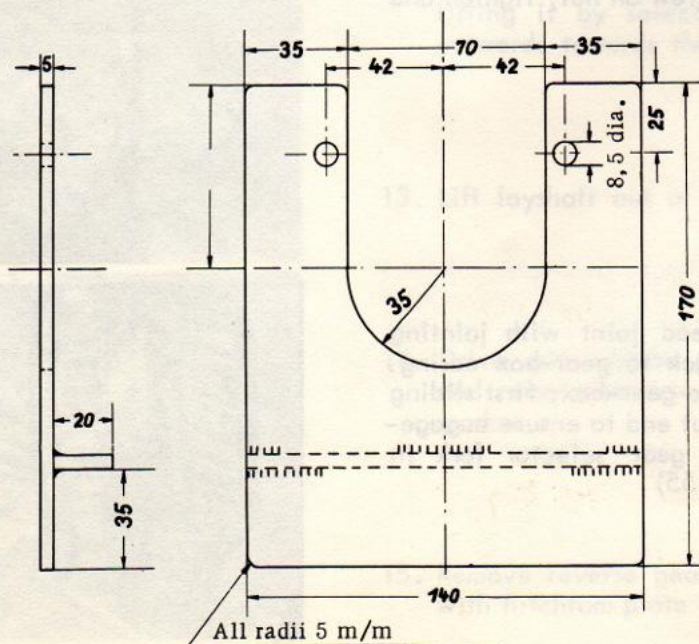

All radii 5 m/m

All measurements in m/m

**Special Tools for
Gear-box Assembly
(Homemade)**

**"Isabella" Gear-box
Dismantling (320 50)
and
Assembly (320 60)**

BKW 1

32-37

3

All measurements in m/m

**Selector Fork
Assembly Drift BW 30**

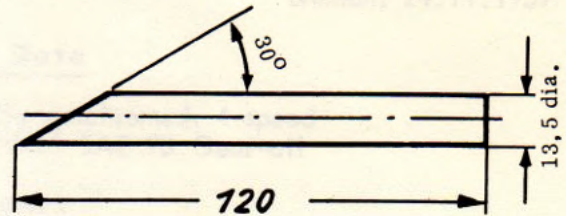

**Packing Ring
Assembly Tool BW 31**

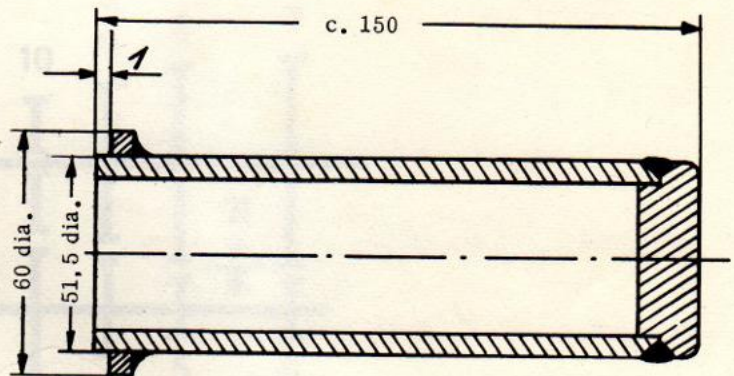

**Mainshaft Ball-race
Assembly Tool BW 32**

