

*Oldtimer-Garage
Henry Preneux*



Mittelweg 95
59302 Oelde
Tel. 02522/62091, Fax 02522/62092
www.borgward-oldtimer.com
E-Mail: info@borgward-oldtimer.com





Erzählende von:
Henry James
Mittelmweg 95
59302 Oelde





Der " Hinterhof "



Im Hintergrund: Parkplatz mit Restaurationsobjekten.

Vorne: Eine neugierige Isabella.

Isabellas Garten

Wir denken weiter und haben Detaillösungen gefunden die keiner hat.
Feste Abdeckung statt einer "Flutterpersenning", welche in den Kofferraum
gelegt werden kann. Auf Wunsch in echtem Leder. Sehen Sie selbst!



Unsere Fahrzeuge sehen auch im geschlossenen Zustand ästhetisch aus. Die Form des Verdeckgestänges haben wir selbst entwickelt. Das Dach verschwindet ganz im Verdeckkasten! Als Rückfenster haben wir eine große Durchsicht gewählt, damit Sie auch geschlossen etwas sehen!









Wer sagt, dass das nicht homogen ist?



Auf dem Wege nach Kalifornien



Kundenwunsch: 166 PS Wänkelmotor, Automatikgetriebe
Servolenkung, Bremskraftverstärker, Breitreifen,
12 Voltanlage, Mittelkonsole, CD-Player
der helle Wahnsinn, wenn das der alte Carl wüsste!



Mittelweg 95
59302 Oelde

Lette
Oelde-3

Sundern

OELDE

Abfahrt Oelde

Tel 06 17 93
02522-62091
Fax
02522-62092

Maßstab 1:20 000

AB-ANSCHLUSS
OELDE



n. Sünninghausen - siehe Nebenkarte -



Info zum Cabriobau in meiner Firma

Lassen Sie sich nichts von den ewigen Besserwissern erzählen.

Ein Isabella Cabriolet, von uns umgebaut, hat den Anspruch auf das „ Historische Kennzeichen „.

Wir haben sowohl für das Coupé-Cabriolet als auch für das Limousinen-Cabriolet ein ausführliches Gutachten, welches den Umbau auf Deutschbasis belegt.

Wir machen auf keinen Fall aus einem Preneux-Umbau einen „original Deutsch-Umbau“. Jeder Kunde erhält das für sein Fahrzeug zutreffende Historische Gutachten vom TÜV.

Wir machen im Prinzip genau das, was die Fa. BORGWARD seinerzeit auch gemacht hat.

Borgward transportierte die Rohkarossen zu der Fa. Karl Deutsch nach Köln und ließ diese dort umbauen. Das war damals üblich. Auch Ford ließ dort umbauen. Die großen Automobilwerke hatten keine eigene Cabrio Fertigung, da diese auf Grund der geringen Stückzahlen nicht hätten wirtschaftlich arbeiten können. Anders bei Daimler Benz.

Der große Unterschied allerdings zu den damaligen Deutsch Umbauten ist, dass wir einen wesentlich höheren Maßstab an die Fertigungsqualität anlegen. Das ist unter Anderem die Rostvorsorge. Bei uns werden alle Schweißnähte versiegelt und die Rohkarosse wird mehrfach mit Rostschutzfarbe gespritzt. Alle Fahrzeugteile erhalten eine hochwertige Antidröhnschutzversiegelung plus einen Farbauftrag.

Unsere Dämmmaterialien entsprechen der heutigen hohen Qualität.

Die B-Säule wird nicht einfach verbreitert, ohne Folgemaßnahmen zu ergreifen. Der Sitz lässt sich trotz des Verdeckscherenbockes ganz nach hinten fahren. Die Coupé Sitzposition bleibt dadurch erhalten. Dieses war nach dem Deutschumbau nicht mehr möglich.

Bei Interesse an meinen Objekten sind Sie herzlich eingeladen.

Artikelübersicht nach Warengruppen

- 1000 = Blechteile
- 2000 = Dichtungen für Türen, Fenster, Karosserie, Blinker, Kofferraum etc
- 3000 = Elektroartikel
- 4000 = Bremsenteile
- 5000 = Kupplungsteile
- 6000 = Motorenteile
- 7000 = Chromteile, Schriftzüge, Zierrat
- 8000 = Innenausstattung, Himmel, Kederband, Scheiben
- 9000 = Hinterachsteile, Gummibälge, Gummipuffer, Kugellager
- 10000 = Vorderachsteile, Kühlkreislaufteile
- 11000 = Schrauben, Rosetten
- 12000 = Anleitungen

Material-Bedarfsliste	Limousine	Coupé
Samtleiste Fensterschacht	63 cm 2 x	77 cm 2 x
Scheibeführungssamtmaterial/U-Profil	220 cm 2 x	--
Dichtung A-Säule/Türscharniersäule	70 cm 2 x	75 cm 2 x
dito Frontscheibe Türspalt S-Form	--	35 cm 2 x
dito Türunterkante	100 cm 2 x	105 cm 2 x
dito zur B-Säule/Türschloss	--	65 cm 2 x
dito hinter der Verkleidung	200 cm 2 x	200 cm 2 x
Kofferdeckeldichtung	400 cm 1 x	450 cm 1 x
Kederband Kotflügel vorne	180 cm 2 x	200 cm 2 x
dito hinten	205 cm 2 x	250 cm 2 x
dito unter der Türblende	105 cm 2 x	--
Windfang Kederband	280 cm 2 x	--
Türdichtprofil	230 cm 2 x	--
Dichtprofil zw. Tür und Kotflügel	75 cm 2 x	65 cm 2 x
Moosgummidichtung Radhaus	350 cm 1 x	350 cm 1 x
dito auf Stehwand, Schottblech u. Türsäule	400 cm 1 x	400 cm 1 x
Frontscheibengummi	400 cm 1 x	400 cm 1 x
Heckfenstergummi, bereits verklebt	1 x	1 x

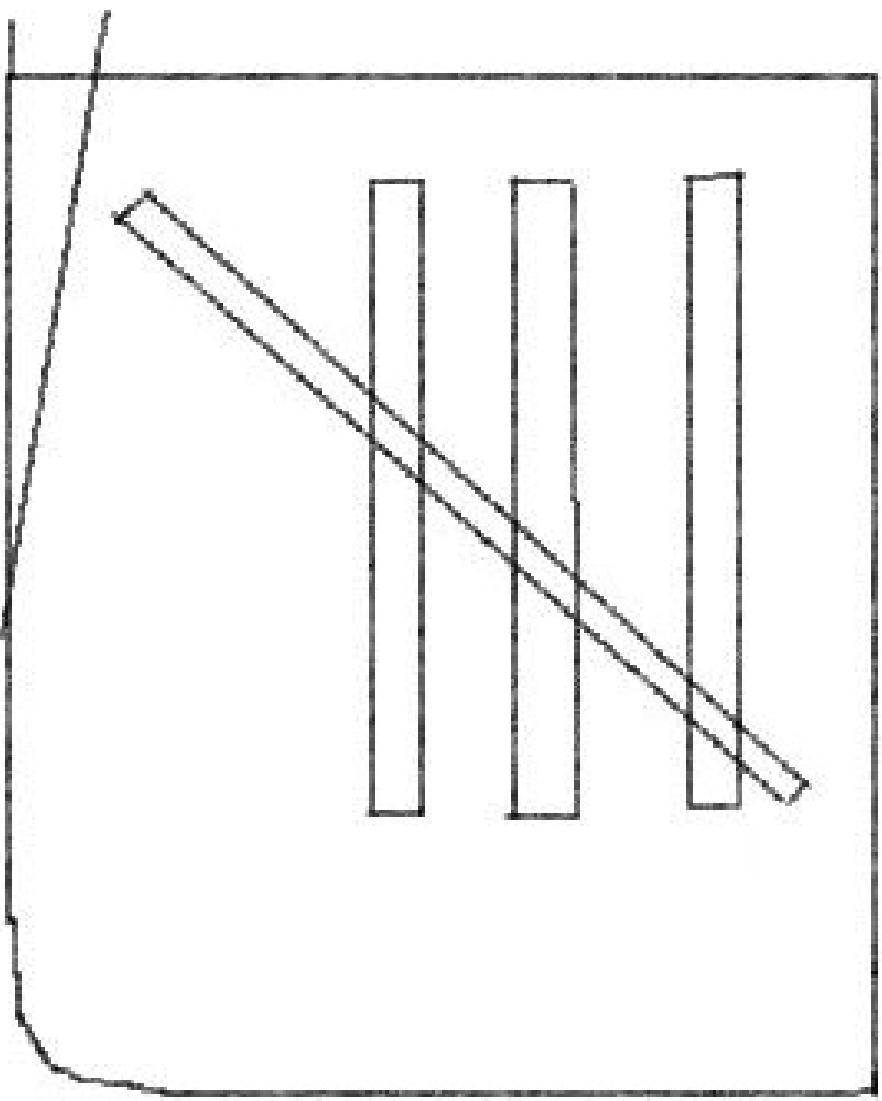

für das Coupé

hier den Verlauf um 1,5 cm ändern

Katossentie



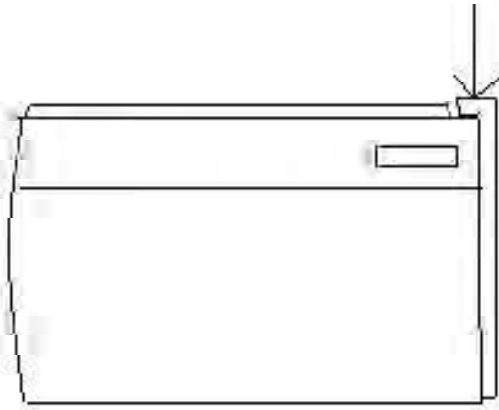

2,5 mm Loch bohren und den Gummi hier abwinkeln. Dazu einen kleinen Keil ausschneiden, damit das Abwinkeln möglich ist.

Im Bereich der Schloßplatte ebenfalls einen Keil ausschneiden.
Dichtung einkleben.

KAROSSERIE
1000

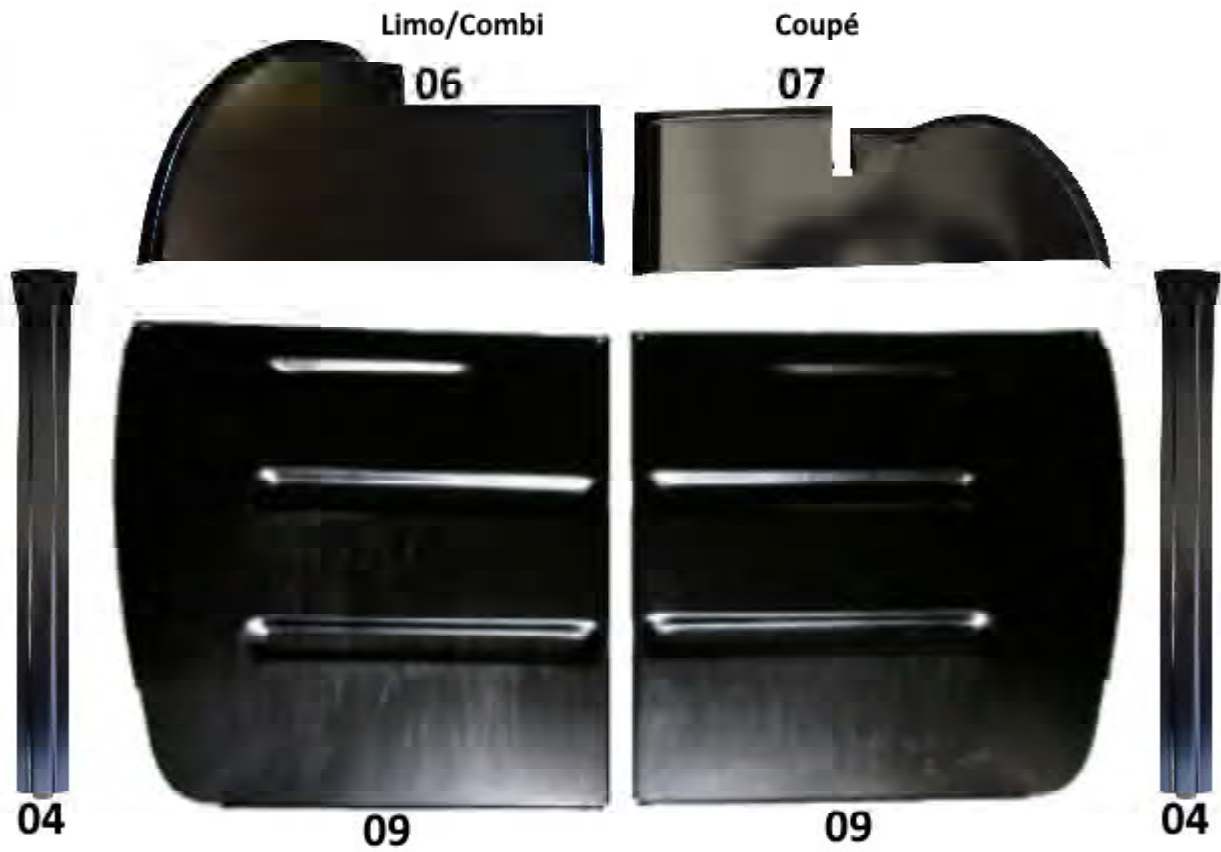
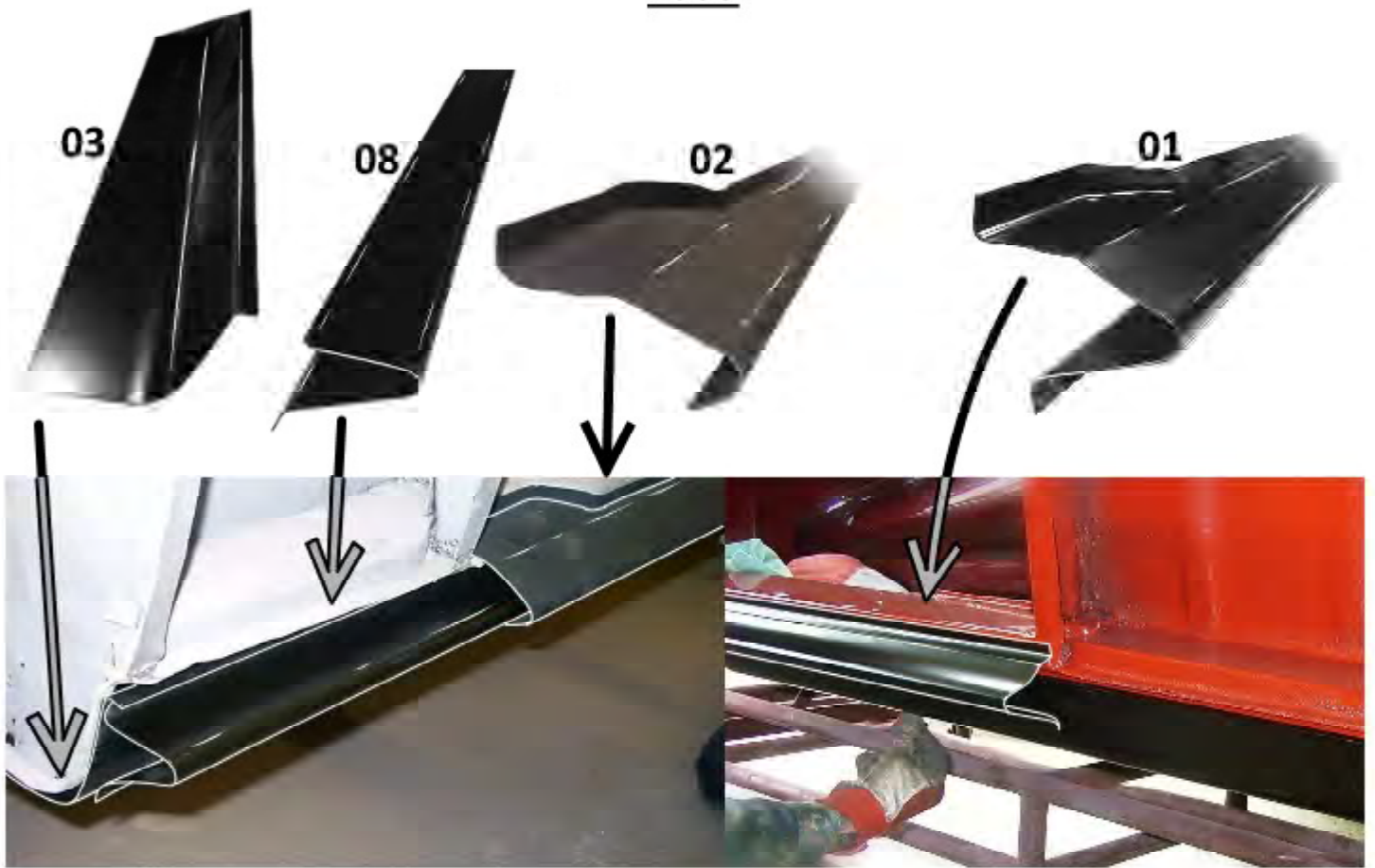

KAROSSERIE
1000

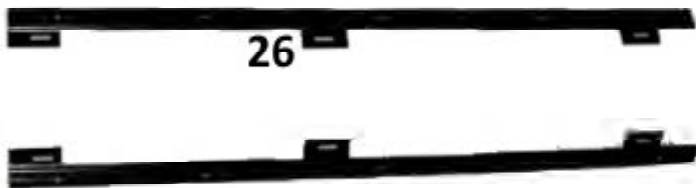
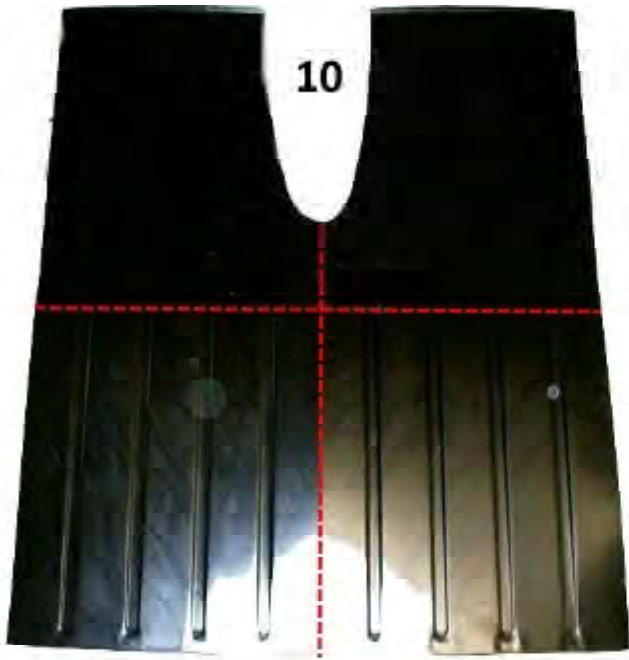

Art. Nr.		Menge		exl. Euro	incl. €
1001	Türschweller Limousine, rechts oder links Rocker plate r / l	St.		32,77	39,00
1002	Türschweller Coupé, rechts oder links Rocker plate r / l	St.		29,41	35,00
1003	Außenholmschale, r / l Sill r / l	St.		32,77	39,00
1004	Versteifungssicke lang / Reinforcement	St.		8,40	10,00
1005		St.			
1006	Schottblech Limousine / Wall in fender l oder r	St.		16,39	19,50
1007	Schottblech Coupé / Wall in fender loder r	St.		16,39	19,50
1008	Schwellerauflageblech Coupé / Reinforcement for sill	St.		24,37	29,00
1009	Stehwand Fuß – Motorraum / Dashbord l oder r	St.		37,81	45,00
1010	Bodengruppe 4-teilig / Floor sektion	St.		150,42	179,00
1011	Kotflügel Kunststoff, Limousine, mit ABE, vorne l oder r Fender plasticreproduktion, sedan front, r oder l	St.		394,95	470,00
1012	wie vor jedoch hinten links Fender plastik rear LH	St.		394,95	470,00
1013	wie vor jedoch hinten rechts, mit Tankklappe Fender plastic rear RH	St.		403,36	480,00
1014	wie vor jedoch Coupé, vorne l oder r Fender plastic, coupé, front r or l	St.		394,95	470,00
1015	wie vor jedoch hinten links Fender plastic, coupé rear LH	St.		394,95	470,00
1016	wie vor jedoch hinten rechts, mit Tankklappe Fender plastic, coupé, rear RH	St.		403,36	480,00
1017					
1018	Kotflügel Kunststoff, P 100 vorne rechts oder links Fender plastic, P 100 front r or l	St.		431,03	500,00
1019	Kotflügelreparaturblech, Lim. vorne, links oder rechts Fender –repairepart, sedan l or r	St.		37,82	45,00
1020	wie vor jedoch Coupé, vorne links oder rechts Fender-repairpart, coupé, front l or r	St.		37,82	45,00
1021	Lampentopf, alle Isabella nicht mehr lieferbar Housing-headlamp, all Isabella not more available	St.			
1022	Türreparaturblech, Coupé Door-repairpart, coupé	St.		29,41	35,00
1023	Karosserie-Seitenteil, Coupé Plate-body, coupé	St.		37,82	45,00
1024					
1025					
1026	Halter Fensterschachtgummi Limousine, rechts oder links Support-window compartment sealing	St.		15,97	19,00
1027	Schaltungskastendeckel im Radhaus links Cover-plate-steeringbox casing	St.		15,97	19,00
1028	Brüstungsleiste-Deckelgummi, Coupé Ledge-rubber, coupé	St.		24,37	29,00
1029		St.			
1030	Seitenblech Boden hinten, rechts oder links Floor plate, rear, without container, l or r	St.		32,77	39,00

Dichtungen



Dichtungen 2000



01+05



03+04



16+18



06



07



08



09



12



13



14



15+38



19



21+23



24



20+22

Dichtungen 2000

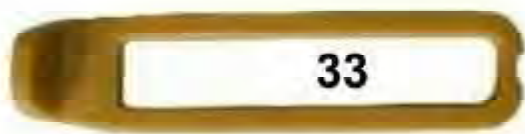
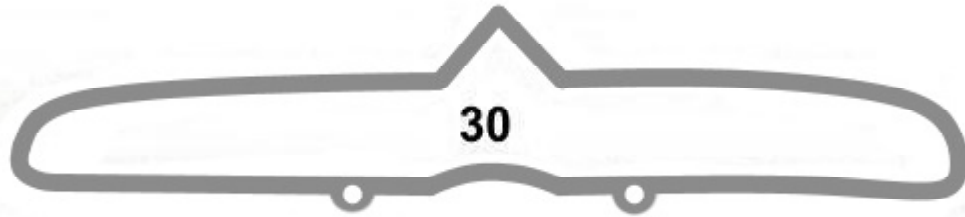
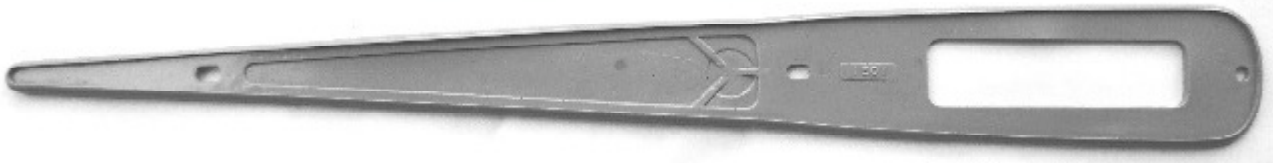

Montagebeispiel



Montagebeispiel



Art Nr.	Artikelbezeichnung/Description	Menge	excl Euro	incEuro
2001	Gummidichtung Kofferdeckel Rubber sealing frame-rear deck lid	Meter	10,08	12,00
2002				
2003	Gummi Türdichtung Limousine Rubber - door weatherstrip	Meter	8,40	10,00
2004	Gummi - Türunterkante Rubber-door,bottom	Stück	8,40	10,00
2005	Gummi - Türdichtung Limousine – vordere Türsäule Rubber door – weatherstrip – front door pillar	Stück	7,56	9,00
2006	Gummi Türdichtung Limousine – Regenleiste vorne Rubber - door weatherstrip – drip moulding front	Stück	8,40	10,00
2007	Gummi - Fensterschacht, Limousine Rubber - window compartment sealing outer	Stück	7,14	8,50
2008	Gummi - Fensterschachtabdichtung, Coupé Rubber - window compartment sealing outer	Stück	9,24	11,00
2009	Gummi – Rahmen Türfenster Coupé Rubber frame – door window	Stück	43,70	52,00
2010	Gummi Türdichtung Coupé, Türscharniersäule, A-Säule Rubber – front door pillar	Stück	7,56	9,00
2011	Gummi – Türdichtung Coupé – Regenleiste vorne Rubber door weatherstrip – drip moulding front	Stück	7,14	8,50
2012	Gummidichtung U-Steg, Seitenfenster Coupé, 325mm Rubber sealing – U-stay/side window	Stück	11,77	14,00
2013	Gummi – Rahmen Coupé, Seitenfenster Festeinbau Rubber frame – side rear window, till August 1960	Stück	25,21	30,00
2014	Gummi – Rahmen Coupé, Seitenfenster schwenkbar außen Rubber frame – side rear window outside, from September 1960	Stück	16,81	20,00
2015	Gummi – Rahmen Coupé, Seitenfenster schwenkbar an Karosserie Rubber frame – side rear window inside	Stück	8,40	10,00
2016	Gummidichtung unter der Türverkleidung, Coupé und Limousine Rubber sealing under the doorpanel	Meter	7,56	9,00
2017	Gummidichtung Windschutzscheibe/Tür Coupé S-Form Rubber sealing windscreen/door s-form	Stück	3,36	4,00
2018	Gummistreifen Hecktür Kombiwagen Rubber sealing door rear – station wagen	Meter	5,88	7,00
2019	Gummi – Türdichtung B-Säule Schloßseite – Coupé, nicht original Rubber door sealing, rear, door pillar/lock side	Stück	7,14	8,50
2020	Gummirahmen Windschutzscheibe Limousine Rubber frame – windscreen sedan and station wagen	Meter	21,00	25,00
2021	wie vor jedoch für Coupé Rubber frame – windscreen coupé	Meter	21,00	25,00
2022	Gummirahmen Rückfenster Limousine Rubber frame – rear window sedan	Stück	63,02	75,00
2023	Gummirahmen Rückfenster Coupé Rubber frame - rear window coupé	Stück	57,98	69,00
2024	Abdichtung im Radhaus Sealing in wheel housing	Meter	10,08	12,00

Art.Nr.	Artikelbezeichnung/Description	Menge	excl.Euro	inclEuro
2026	Unterlage Blinker vorne oben Packing – blinker lamp front to fender	Stück	22,69	27,00
2027	Unterlage Blinker hinten Packing – blinker rear	Stück	26,89	32,00
2028	Unterlage Blinkleuchte unten, Limousine und Kombiwagen Packing – blinker lamp, bottom	Stück	11,72	14,00
2029	Pedal gummi Pedal pad – break and clutch	Stück	14,70	17,50
2030	Unterlage Kofferdeckelgriff Packing – lincense lamp – trunk lid	Stück	15,97	19,00
2031	Unterlage Haubenfigur – Motorhaube Packing – hood motiv	Stück	12,61	15,00
2032	Unterlage Spiegelfuß Packing mirror	Stück	6,72	8,00
2033	Moosgummieinlage Blinker vorne Sealing blinker parking lamp – front	Stück	11,76	14,00
2034	wie vor, jedoch hinten Sealing blinker lamp rear – inside	Stück	1,01	1,20
2035	Schutzkappe – Blinkleuchte vorne unten Protection cap – blinker lamp, bottom	Stück	6,72	8,00
2036	Dichtstreifen Stehwand, Türsäule, Kotflügel Rubber sealing – wall in fender, pillar, dash bord	Meter	2,41	2,80
2037	Unterlage Rückstrahlergehäuse, schwarz Seal – tail lamp housind – reflektor	Meter		n.l.
2038	Gummidichtung Schwenkfenster an Karosserie, Limousine Rubber frame – side rear window an body	Stück	14,71	17,50
2039	Türgriffunterlage 2-tlg, für einen Griff Door handle packing	Satz	9,03	10,75
2040	Rosette Tankeinfüllstutzen	Stück	15,97	19,00
2041	Gummiprofil Schwenkfenster, Coupé oder Lim. im Scheibenrahmen Rubber frame coupé or sedan, side rear window, between glas and steel	Meter	6,30	7,50

Elektrik

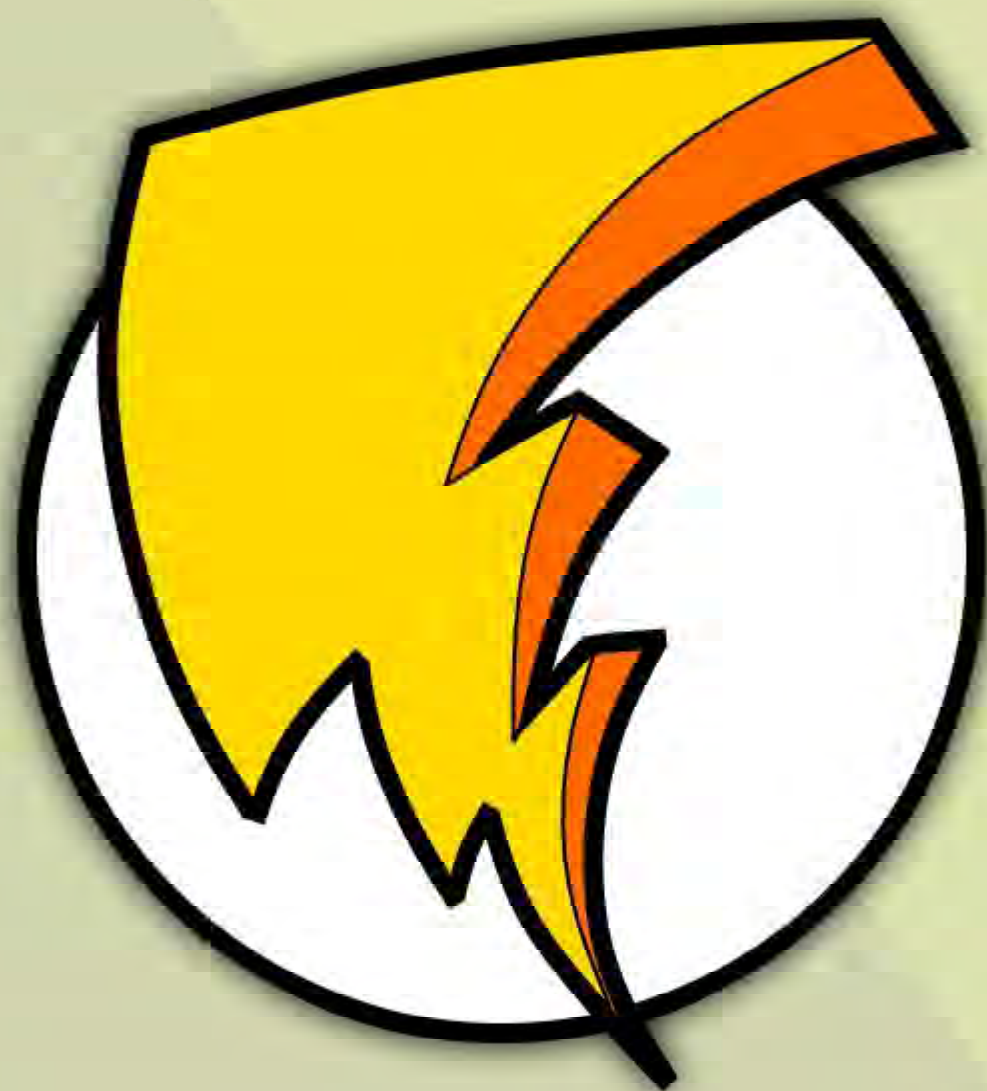

Elektrik 3000



01



03



05



07



08



09



10



11



12



13



14



16



19

17



18



22



22



23



28



31



32

Elektrik 3000



Art. Nr.	Artikelbezeichnung/Description	Menge	Eur excl	Euro incl
3001	Reflektor Hauptscheinwerfer Hella, mit wenigen Änderungen einzubauen	St.	57,98	69,00
3003	Glühlampe 6 Volt 60/55Watt H4	St.	15,13	18,00
	Bulb, Headlamp Halogen			
3004	Lichtschalter Limousine, 4 Anschlüsse	St.		
	Pulltype switch headlight, sedan			
3005	Zündanlassschalter Limousine – 1961, mit 2 Schlüsseln	St.	50,86	59,00
	Ignition lock with 2 keys			
3006	Haltering, BOSCH nicht mehr lieferbar	St.		
	Rim, Bosch			
3007	Drucktastenstecker alle Modelle	St.	7,56	9,00
	Push – key plug			
3008	Glühlampe Hauptscheinwerfer, 6V 40/45 W	St.	5,67	6,75
	Bulb Headlamp			
3009	Glühlampe 6V 18 W	St.	2,94	3,50
	Bulb – Stopp and blinker lamp			
3010	Glühlampe 6V 4 W	St.	2,10	2,50
	Bulb – parking lamp			
3011	Glühlampe 6V 5 W	St.	2,77	3,30
	Bulb – tail or license plate lamp			
3012	Glühlampe Deckenleuchte Lim. 6V 3 W	St.	2,10	2,50
	Bulb – roof lamp sedan			
3013	Glühlampe Deckenleuchte coupé 6V 5 W	St.	2,77	3,30
	Bulb – roof lamp coupé			
3014	Glühlampe, Instrumentenbeleuchtung 6V 1,2 W oder 2 Watt	St.	1,26	1,50
	Bulb – instrument panel lamp			
3015	Glühlampe Blinker unten, Sofitte 6V 18 W	St.	3,36	4,00
	Bulb – only for Germany			
3016	Zündkerzenstecker 1 Ohm	St.	5,80	6,90
	Sparking plug			
3017	Starterbatterie 6V / 84 Amp.	St.	159,66	190,00
	Battery all Isabella			
3018	Unterbrecherkontaktsatz	St.	7,48	8,90
	Beaker point			
3019	Verteilerkappe	St.	16,81	20,00
	Distributor cap			
3020	Innenleuchte Coupé nicht mehr lieferbar	St.		
	Roof lamp – coupé			
3021	Scheinwerfereinsatz nicht mehr lieferbar	St.		
3022	Rückstrahlereinsatz, nicht original aber gut, große Ausführung	St.	12,61	15,00
	Reflektor 2. version			
3023	Rückstrahlereinsatz, Nachfertigung, ohne Chromrahmen, große Ausf.	St.	19,82	23,00
	Reflektor – reproduktion, without chromring, 2. version			
3024	Scheibenwischerblatt, Hakenbefestigung, nicht original, schwarz		15,52	18,00
	Wiper blad – not original, black			
3025	Wischerarm, silber kein Chrom, Hakenbefestigung nicht mehr lieferbar			
	Wiper arm, not original			

Art. Nr.	Artikelbezeichnung/Description	Menge	excl. Euro	Euro
3028	Türkontaktschalter Door light switch	Stück	15,12	18,00
3029		St.		
3030	Wischerachse, Coupé nur im Austausch Wiper operatind rod, send the old part to rebuild	St.	29,41	35,00
3031	Batteriemasseband, 200mm Connecting – batterie ground to body	St.	11,77	14,00
3032	Getriebemasseband, 200mm Connecting gear to body	St.	8,40	10,00
3033	Sicherungskasten 12 polig Fuse box	St.	29,41	35,00
3034	dto. jedoch 2 polig same but 4 poles	St.	6,72	8,00
3036	Rückwärtsgangschalter – Rückfahrcheinwerfer Switch on gearbox – backlight	St.	29,41	35,00
3038	Kugellager Lichtmaschine Ball bearing generator	St.	6,72	8,00
3039	Kohlebürste Lichtmaschine Brushes – generator	Satz	10,08	12,00
3040	Kohlebürste Anlasser 4-tlg Brushes – starter	Satz	15,13	18,00
3041	Zündkerze 175 T 1, für 60 PS-Motor Sparking plug – 60 HP	St.	3,78	4,50
3042	Zündkerze 225 T 1, für 75 PS-Motor Sparking plug – 75 HP	St.	3,78	4,50
3045	Spritzdüse 2-strahlig nicht mehr original, jedoch sehr schön und verstellbar	St.	24,37	29,00
3049	Blinkgeber 6V 10 – 110 Watt, elektronisch Blinker relaise	St.	37,03	42,95
3050	Verteilerfinger – Zündverteiler Rotor – distributor	St.	10,08	12,00
3051	Bremslichtschalter – am Ringstutzen Stop light switch – connection	St.	12,90	14,50
3052	Kondensator – Zündverteiler Condenser – distributor	St.	6,72	8,00
3053	Tellerhorn 6 Volt schwarz, Tiefton 350 Hz Disc type horn not more deliverable	St.	57,98	69,00
3054	Regler 6 Volt, alle Isabella nicht mehr lieferbar Regutator not more deliverable	St.	0,00	0,00
3055	Warnblinkanlage 6 Volt von Bosch wie Original mit Klemme 54 f Warning blink light	Set	74,79	89,00
3056	Tankgeber universal 6-24 Volt Lever tank sensor	St.	71,43	85,00
3057	Zündspule – Hochleistungsz. 6 Volt Ignition coil	St.	57,98	69,00
3058	Lichtschalter Isabella Lim. Kl. 30, 56, 57, 58 Switsch for Headlight	St.	21,01	25,00
3059	Fußblendeschalter Klemme 56, 56, 56b	St.	29,41	35,00
3060	Tankgeber Universal 10-180 Ohm 6-24 Volt Lever tank sensor wegen schlechter Qualität aus dem Sortiment genommen	St.	00,00	00,00

Brems- anlage



Bremsenteile 4000

bitte unbedingt die FG.Nr. angeben!

Bj. 1960-1962

Bj. 1954-1960

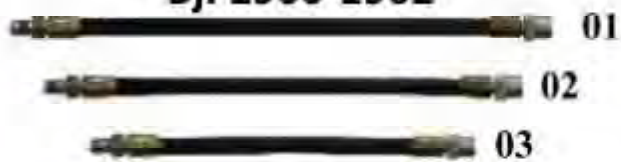

Art. Nr.	Artikelbezeichnung/Description	Menge	excl. Euro	Euro
4001	Bremsschlauch vorne, 500mm Bj. 60 - 62 Brake hose, front	Stück	15,15	18,00
4002	Bremsschlauch hinten, links 380mm BJ. 60 - 62 Break hose, rear LH	St.	12,61	15,00
4003	Bremsschlauch hinten, rechts 241mm BJ. 60 - 62 Break hose, rear RH	St.	11,76	14,00
4004	Bremsschlauch vorne, 500mm Bj. 54 - 60 Brake hose, front	St.	15,15	18,00
4005	Bremsschlauch hinten, links 380mm BJ. 54 - 60 Break hose, rear LH	St.	14,29	17,00
4006	Bremsschlauch hinten, rechts 241mm BJ. 54 - 60 Break hose, rear RH	St.	13,45	16,00
4007	Bremsbelag aufnietbar – asbestfrei, Satz = 4 Belag incl. Nieten für 1 Achse Break lining bitte unbedingt das Baujahr angeben	Satz	50,42	60,00
4008	Rohrniet Kupfer Rivet – lining to break shoe	St.	0,10	0,12
4009	Bremsschlauchhalter/Gabel für Bj. 54 - 60 Holder – break hose	St.	2,48	2,95
4010	dito, Baujahr ab 1960 same but from 1960 til 1962	St.	1,77	2,10
4011	Manschette Radbremszylinder, 28mm Cup – wheel cylinder, important: body identifikations number to give	St.	5,88	7,00
4012	dito 25,00mm	St.	5,88	7,00
4013	dito 22,00	St.	5,88	7,00
4014	dito 20,00	St.	5,88	7,00
4015				
4016				
4017				
4018	Entlüfterventil 6mm, mit Staubkappe Bleeder valve with dust cap	St.	4,96	5,90
4019	Bremsrohrsatz Stahl, 4,75mm Break pipe, steel	St.	31,93	38,00
4020	Bremsrohrsatz Stahl, 6,00mm Break pipe, steel	St.	37,81	45,00
4021	Leitung vorn – Trommel – Zylinder zu Zylinder, alle Modelle Break pipe front – brake drum – wheel cylinder, al models	St.	5,17	6,00
4022	Entlüfterventil 10mm, mit Staubkappe Bleeder valve with dust cap	St.	4,96	5,90
4023	Entlüfterventil 8mm, mit Staubkappe Bleeder valve with dust cap	St.	4,96	5,90
4024	Schutzkappe Radzylinder 28mm Dust cap wheel cylinder	St.	10,08	12,00
4025	Schutzkappe Radzylinder 25mm Dust cap wheel cylinder	St.	7,56	9,00

Art. Nr.	Artikelbezeichnung/Description	Menge	excl. Euro	Euro
4026	Schutzkappe Radzylinder, 22mm – Hinterachse, BJ 54 - 60 Cap wheel cylinder	St.	7,14	8,50
4027	Schutzkappe Radzylinder, 20mm – Hinterachse, BJ 60 - 62 Cap wheel cylinder	St.	7,14	8,50
4028	Radzylinder, neu Nachfertigung 28,57mm vorne Wheel cylinder, new	St.	66,39	79,00
4029	Radzylinder, neu 25,40 mm vorne Wheel cylinder, new	St.	66,39	79,00
4030	Radzylinder, neu 22,20 mm vorne Wheel cylinder, better then new	St.	66,39	79,00
4031	Radzylinder, neu Nachfertigung 22,20 mm hinten Wheel cylinder, better then new	St.	66,39	79,00
4032	Radzylinder, neu Nachfertigung 20,64 mm hinten Wheel cylinder, better then new	St.	66,39	79,00
4033	Reparatursatz Hauptbremszylinder, Bj. 54 – 60, mit Kolben Repair set brake master cylinder, 54 – 60, inclusive pisten	Satz	37,82	45,00
4034				
4035	Hauptbremszylinder Bj. 54 – 60, ohne Abzweige/Adapter Brake master cylinder bis 8/60	St.	82,35	98,00
4036	Hauptbremszylinder, Bj. 60 – 62 neu Nachfertigung Brake master cylinder ab 9/60	St.	125,21	149,00
4037	Adapter Hauptbremszylinder Bj. 54 – 60 Distributor b m c	St.	32,77	39,00
4038	Verteiler Bremsrohr Hinterachse M 12 x 1,00 mm 54 - 60 Distributor	St.	15,00	17,85
4039	Verteiler Bremsrohr Hinterachse M 10 x 1,00 mm 60 - 62 Distributor	St.	15,00	17,85
4040	Hohlschraube - Verteiler Bremsrohr Hollow bolt b m c	St.	5,84	6,95
4041	Kupferdichtscheibe – Hohlschraube Packing ring for hollow bolt	St.	0,78	0,90
4042	Bremsölbehälter, für Brems- u. Kupplungszyylinder, Kunststoff Fluid container – brake and clutchcylinder	St.	32,77	39,00
4043	Handbremsseil einteilig, Bj. 54 – 60 Hand brake cable	St.	79,83	95,00
4044	Handbremsseil 2 – teilig Bj. 60 – 62 Hand brake cable	St.	82,35	98,00
4045	Faltenbalg – Durchführung Bremsbackenhebel Rubber bellow – brake scoe lever	St.	11,77	14,00
4046	Fächerscheibe A 12,5 DIN Spring washer	St.	1,12	1,30
4047	Sicherungscheibe 12 DIN Lock plate	St.	1,12	1,30
4048	Senkschraube AM 6 x 10 Filister screw – brake drum to axle shaft	St.	0,56	0,65

Kupplung



Kupplung 5000



01



02



03



04



09



10



05



08



24



19



11



13



14



15



25

Art. Nr.	Artikelbezeichnung/Description	Menge	excl. Euro	Euro
5001	Kupplungsmittnehmerscheibe im Tausch, F&S Clutch plate, exchange	Stück	74,79	89,00
5002	Druckplatte im Tausch, F&S Clutch pressure plate, exchange	Stück	100,00	119,00
5003	Ausrücklager, F&S Clutch bearing	Stück	90,00	107,00
5004	Verbindungsschlauch 200 mm Hose, between clutch cylinder	Stück	14,71	17,50
5005	Manschette Nehmerzylinder Rubber seal	Stück	6,30	7,50
5006				
5007				
5008	Zug- und Druckkabel für Gangwahl Push- and pull cable for selective movement	Stück	49,58	59,00
5009	Verbindungsrohr – Zylinder – Schlauch connection pipe – cylinder-hose	Stück	4,83	5,75
5010	Kupplungsnehmerzylinder Clutch cylinder	Stück	88,24	105,00
5011	Kupplungsgeberzylinder Clutch master cylinder	Stück	82,35	98,00
5012	Reparatursatz Geberzylinder, ohne Kolben, nicht mehr lieferbar Repairset master cylinder	Satz		
5013	Lagerbüchse an Schalthebel Bearing bush, shifter	Stück	6,98	7,95
5014	Lagerbüchse – Lagerblech an Schaltrohr Bearing bush – bearing plate to gear change tube	Stück	6,98	7,95
5015	Muffe elastisch an Getriebehebel Rubber sleeve – gear lever inner	Stück	6,98	7,95
5016				
5017				
5018	Schalthebelknopf, unlackiert Gear lever button	Stück	13,36	15,50
5019	Entlüftungsventil – Kupplungsnehmerzylinder Bleeder valve – clutch cylinder	Stück	4,96	5,90
5020				
5021				
5022	Schutzkappe zu 5010 Dust cap to 5010	Stück	10,92	13,00
5023				
5024	Kugelpfanne mit Sicherungsbügel Ball cup with locking clip	Stück	4,16	4,95
5025	Faltenbalg Schalthebel Bellow	Stück	11,77	14,00

Motorer- teile

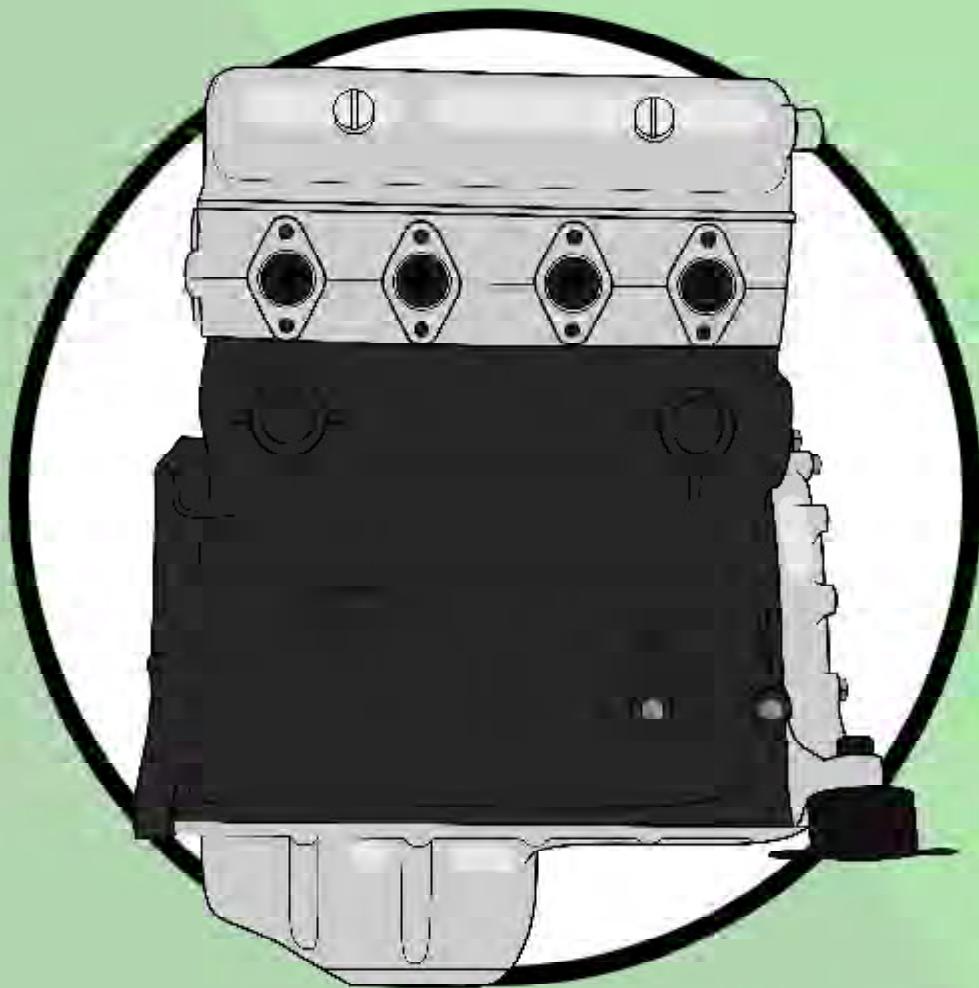

Diese Abgasanlage von ist Hand gefertigt!

Alle Teile sind großzügig bemessen.

Der Bogen am Vorschalldämpfer hat mit Absicht Überlänge. Da durch ist gewährleistet, dass die Anlage für jede Isabella passt!

Wenn notwendig, trennen Sie ein Stück von ca. 6 cm ab.

Das lange Rohr wird in die Schiebemuffe am Vorschalldämpfer eingeführt. Somit kann die Gesamtlänge variiert werden.

Die Anlage wird zuerst komplett und lose hängend montiert. Dann den korrekten Sitz ermitteln und anzeichnen. Danach den Vorschalldämpfer mit dem langen Rohr verschweißen. Wenn kein Schweißgerät vorhanden, die Muffe am Vorschalldämpfer schlitzen und mittels einer Rohrschelle klemmen.

Das Anhängblech auf die Schiebemuffe schweißen oder eine Klemme richtig positionieren.

Den Endschalldämpfer so platzieren, dass dieser keinesfalls mit den Bauteilen der Hinterachse in Berührung kommt.

Diese Abgasanlage zeichnet sich durch einen angenehmen dumpfen Klang aus und wird Ihnen sicher viel Freude bereiten.

Ihre Oldtimer-Garage Henry Preneux

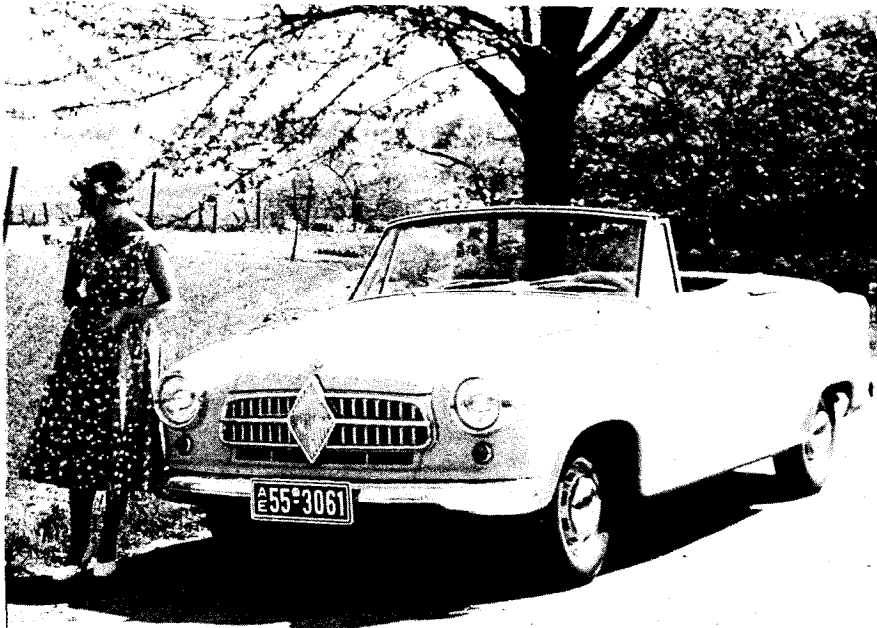

Abgasanlage Isabella

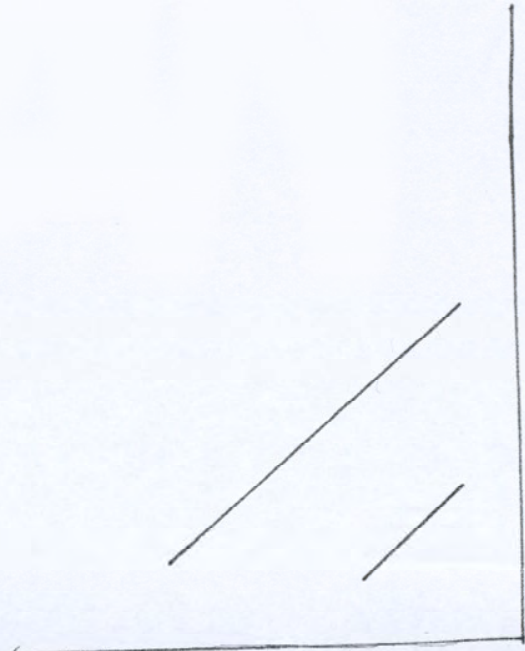
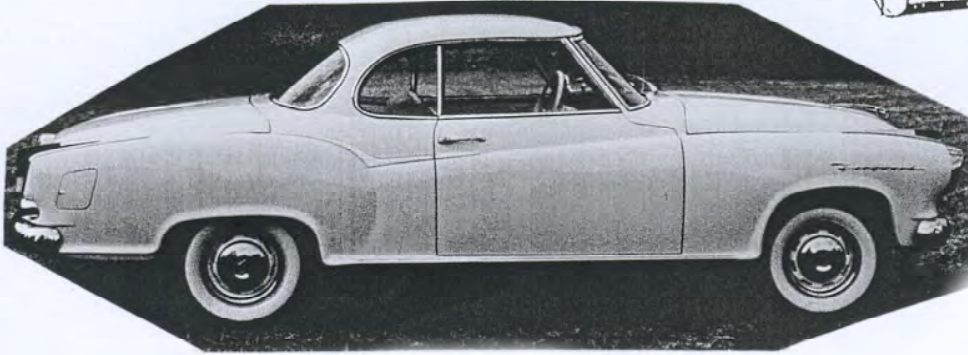
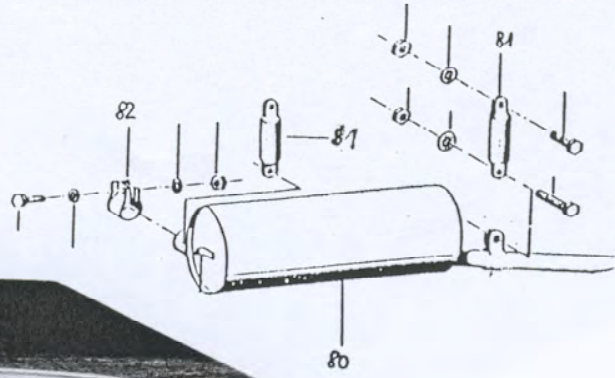
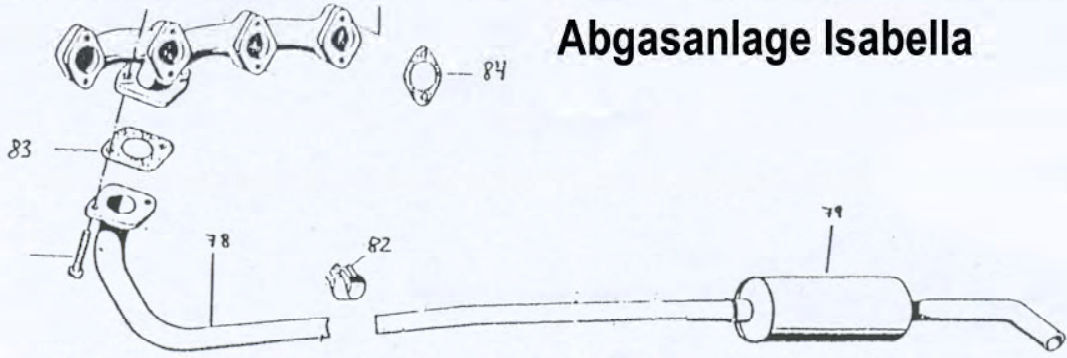

Motorenteile 6000



Motorenteile 6000

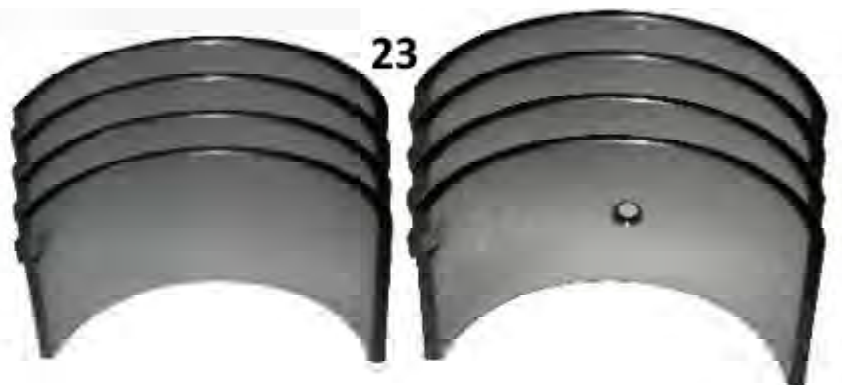
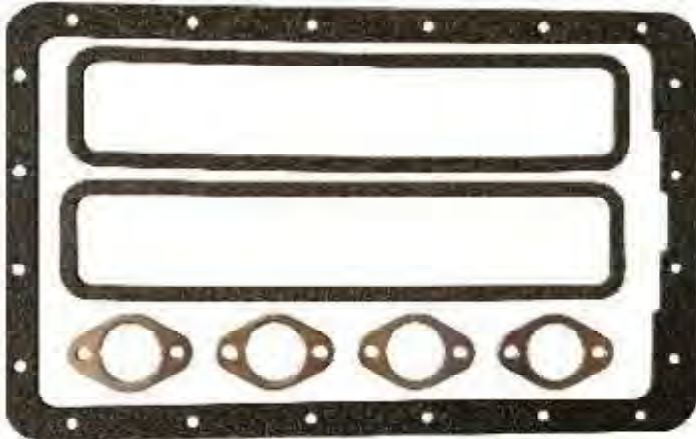

Motorenteile 6000



Benzinpumpenreparatursatz:6030



Motorenteile 6000

98



81



82



83



91



84



86



85



88

92



93



94



95



Motorenteile 6000

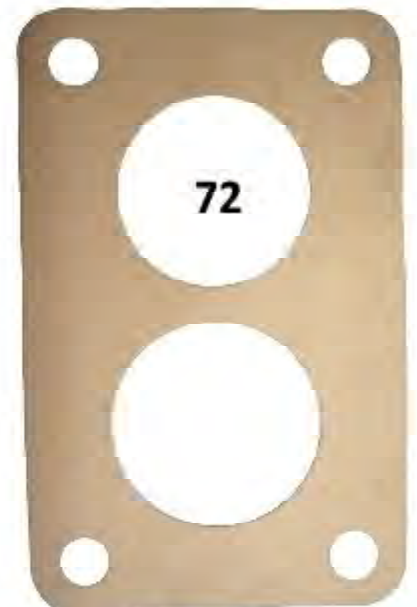
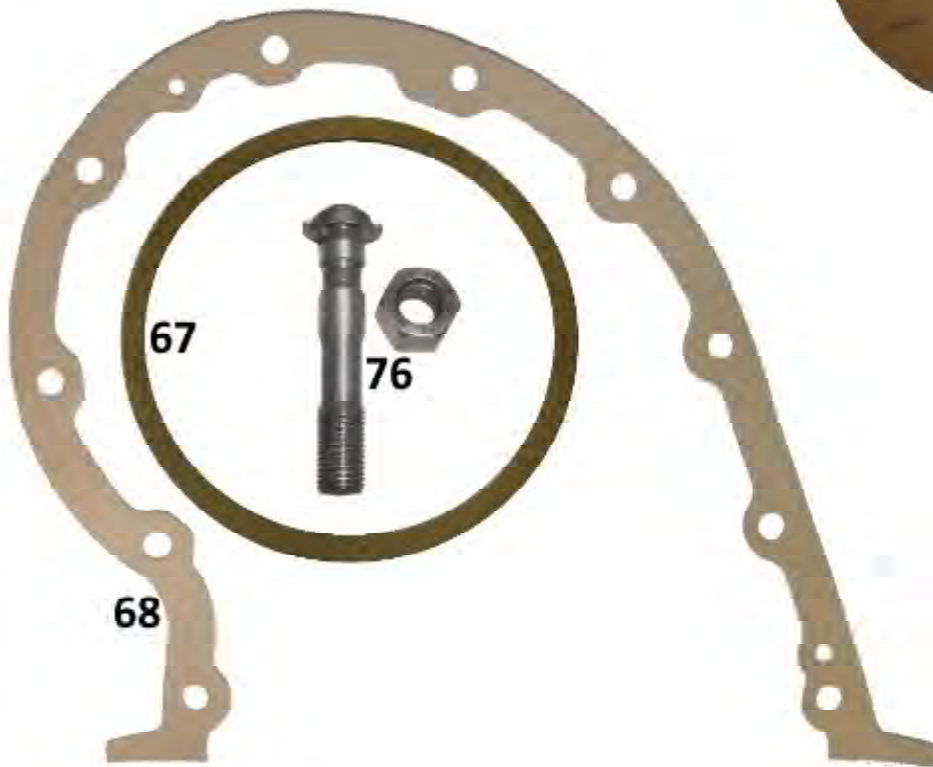
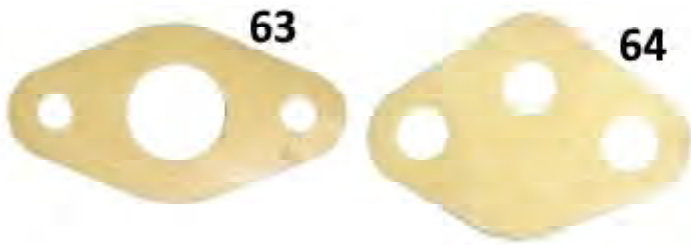

Art. Nr.	Artikelbezeichnung/Description	Menge	excl. Eu	Euro
6001	Zylinderkopfdichtung Cylinder head gasket	St.	37,82	45,00
6002	Dichtung – Zylinderkopfhaube Gasket – rocker gear cover	St.	16,39	19,50
6003	Inspektionsdeckeldichtung Gasket – side cover	St.	8,82	10,50
6004	Einlassventil 75 PS – schmale Nut Inlet valve	St.	32,77	39,00
6005	Auslassventil 75 PS – schmale Nut Exhaust valve	St.	32,77	39,00
6006	Motordichtsatz mit Krümmerdichtungen Gasket set for Isabella	St.	113,45	135,00
6007		St.		
6008				
6009				
6010				
6011	Ventilführungsrohr Valvs guid – inlet and outlet valve	St.	13,45	16,00
6012				
6013				
6014				
6015				
6016	Nockenwellenrad inclusive Kurbelwellenrad Camshaft timing gear	Satz.	142,24	169,00
6017	Kurbelwellenrad Timing gear – crankshaft	St.	50,86	59,00
6018				
6019	Dichtring Kipphebelfuß Sealing ring – braket	St.	2,16	2,50
6020				
6021	Dichtung Öldunstentlüfter Gasket	St.	2,31	2,75
6022	Dichtung – Ansaugrohr/Zylinderkopf Gasket – inled manifold to cylinder head	St.	10,08	12,00
6023	Pleuellagersatz 0,00 / 0,25 / 0,50 / 0,75 Big end bearing – shell top and bottom	Set	75,63	90,00
6024	Kurbelwellenlagersatz 0,00 / 0,25 / 0,50 / 0,75 Main bearing – shel top and bottom	Set	84,03	100,00
6025	Dichtung – Ölwanne Gasket – oil pan	St.	17,24	20,00

Art. Nr.	Artikelbezeichnung/Description	Menge	excl.Euro	Euro
6026	Filzdichtung Kurbelwelle Felt ring	St.	7,56	9,00
6027	Federscheibe B 8 DIN 137 Spring washer	St.	0,22	0,25
6028	Dichtring C 10 x 14 Sealing ring	St.	0,78	0,90
6029				
6030	Benzinpumpenreparatursatz Membrane fuel pump, Set	St.	57,98	69,00
6031	Isolierflansch Benzinpumpe Insulating flange	St.	10,08	12,00
6032	Dichtung – Kraftstoffpumpe an Zylinderblock Gasket – fuel pump	St.	1,72	2,00
6033	O-Ring Vergaserfuß an Zylinderkopfhaube Sealing ring – intermediate flange rocker gear cover	St.	3,78	4,50
6034	O-Ring wie vor same but	St.	2,10	2,50
6035	Gummidichtring – Luftfilter/Vergaser Rubber sealing ring – air filter	St.	12,60	15,00
6036	Gummidichtring – Luftfilter/Vergaser Rubber sealing ring – air filter	St.	12,60	15,00
6037	Gummidichtring – Luftfilterdeckel Rubber sealing ring, outer – air cleaner	St.	4,62	5,50
6038	wie vor jedoch same but	St.	3,78	4,50
6039	Faltenbalg TS – Vergaser Rubber bellow – shock absorber caburettor – TS	St.		n.l.
6040	Dichtung – Entlüftungsrohr Sealing ring – breather pipe	St.	1,85	2,20
6041	Dichtung – Vergaserfuß/Haube Gasket – carburettor to rocker gear cover	St.	1,85	2,20
6042	Dichtung – Gasregulierung an Zylinderkopfhaube Gasket – gas control to rocker gear cover	St.	1,85	2,20
6043				
6044				
6045				
6046				
6047				
6048	Kurbelwellenlagerbuchse Bush	St.		n. l.
6049	Pleuellagerbuchse Small end bush	St.	10,08	12,00
6050				

Art. Nr.	Artikelbezeichnung/Description	Menge	excl.Eu	Euro
6051	Kolben mit Ringen und Bolzen – 75,00 / 75,50 / 76,00 / 76,50mm, Preis per Kolben Piston 75,00 – 76,50,	Stück	100,84	120,00
6052	Kolbenringsatz für 4 Kolben Pistonringset	Satz	126,05	150,00
6053	0 – Ring Ölsteigbohrung Zylinderkopfdichtung, 3 x 7 Sealing ring	St.	1,29	1,50
6054	Dichtung Abdeckflansch Gasket – cover flange	St.	1,68	2,00
6055	Abstellhahn Heizungssystem, nicht mehr lieferbar Stop cock – heating system	St.	0,00	0,00
6056				
6057	Dichtung Lagerbockfuß an Zk - Ölsteigbohrung Sealing ring	St.	1,68	2,00
6058	Dichtring C 14 x 18 Sealing ring	St.	1,47	1,75
6059	Nockenwellenlagesatz Camshaft bearing 1. 2. and 3.	St.	42,00	50,00
6060	Antriebsrad – Ölpumpen- und Verteilerantrieb Spiral wheel	St.	25,21	30,00
6061	Ölpumpenzahnrad – Welle Oil pump gear – shaft	St.	23,53	28,00
6062	Ölpumpenzahnrad – Lagerbolzen Öil pump gear – idler wheel pin	St.	23,53	28,00
6063	Dichtung - Ansaugkorb an Ölpumpe Gasket – inlet bel to oil pump	St.	1,77	2,10
6064	Dichtung – Ölpumpe an Block Gasket – oil pump to cylinderblock	St.	1,77	
6065	Ölfiltereinsatz Originalteil Filter element	St.	11,35	13,50
6066	Dichtung – Nebenstromfiltergehäuse an ZK Gasket – by-flow filter to cylinder head	St.	9,24	11,00
6067	Dichtring – Deckel Ölfiltergehäuse Sealing ring	St.	1,68	2,00
6068	Stirndeckeldichtung Gasket – timing gear cover	St.	10,08	12,00
6069	Öldruckschalter Oil pressure switch	St.	12,60	15,00
6070	Federscheibe, B 8 – Befestigung Ölwanne Spring washer – attachment – oil pan	St.	0,17	0,20
6071	Dichtung – Vergaserdeckel 75 – 100 PS Gasket – carburettor	St.	5,88	7,00
6072	Dichtung Vergaser an Zwischenflansch Gasket – carburettor to intermediate flange	St.	4,20	5,00
6073	Dichtung – Vergaserfuß Gasket – carburettor	St.		n.l.
6074	Dichtung – Vergaserdeckel 60 PS Gasket – carburettor	St.	5,04	6,00
6075	Kugelkopf – Vergasergestänge M 5 Ball cup with locking clip	St.	4,20	5,00

Art. Nr.	Artikelbezeichnung/Description	Menge	excl. Eur	Euro
6076	Pleuelschraube Connecting rod bolt	St.	10,08	12,00
6077	Auspuffanlage – von vorne bis hinten, Komplettsatz Preisvorteil Exhaust - front to rear	St.	231,09	275,00
6078	Auspuffkrümmer, 2 verschiedene Winkel, Bj. angeben! Exhaust manifold	St.	50,42	60,00
6079	Auspuffleitung mitte, mit Vorschalldämpfer Exhaust pipe, center including pre – silencer	St.	117,65	140,00
6080	Endschalldämpfer Silencer	St.	82,35	98,00
6081	Gummiaufhängung - Schalldämpfer Suspension rubber	St.	12,61	15,00
6082	Auspufftopfschelle Silencer clump	St.	4,20	5,00
6083	Dichtring – Auspuffleitung vorn an Krümmer Seal – exhaust pipe, front to manifold	St.	6,30	7,50
6084	Dichtung – Auspuffkrümmer an Zylinderkopf Gasket – exhaust manifold to cylinder head	St.	2,94	3,50
6085	Tankdeckel alle Isabella Filler cap-fuel tank	St.	8,40	
6086	Hohlschraube – Vergaser/Benzinpumpe Bolt - Hex. Fuel pump/karburator	St.	3,36	4,00
6087	Tankdeckel Isabella abschließbar mit 2 Schlüsseln Filler cap - fuel tank lokable	St.	32,77	39,00
6088	Dichtung Tankgeber Gasket – fuel tank gau	St.	3,36	4,00
6089	Dichtung Kraftstoffentnahmestutzen Gasket – fuel outlet pipe	St.	3,36	4,00
6090	Ölschleuderring oil – flinger ring	St.	8,40	10,00
6091	Ölablaßschraube Plug – drain	St.	4,31	5,00
6092	Dichtung – Membranpumpe, vorne 75 - PS Vergaser Gasket – starter pump, front	St.	5,88	7,00
6093	Dichtung – Membranpumpe, hinten 75 - PS Vergaser Gasket – starter pump, rear	St.	5,88	7,00
6094	wie 6092, jedoch für 60 PS – Vergaser same like 6092	St.	5,60	6,50
6095	wie 6093, jedoch für 60 PS – Vergaser same like 9093	St.	5,60	6,50
6096	Halteflansch – Nockenwelle Supporting – flange	St.	18,49	22,00
6097	Ablasshahn nicht mehr lieferbar Drain tap	St.		
6098	Anlasserzahnkranz Starter ring gear	St.	92,44	110,00

Chromteile

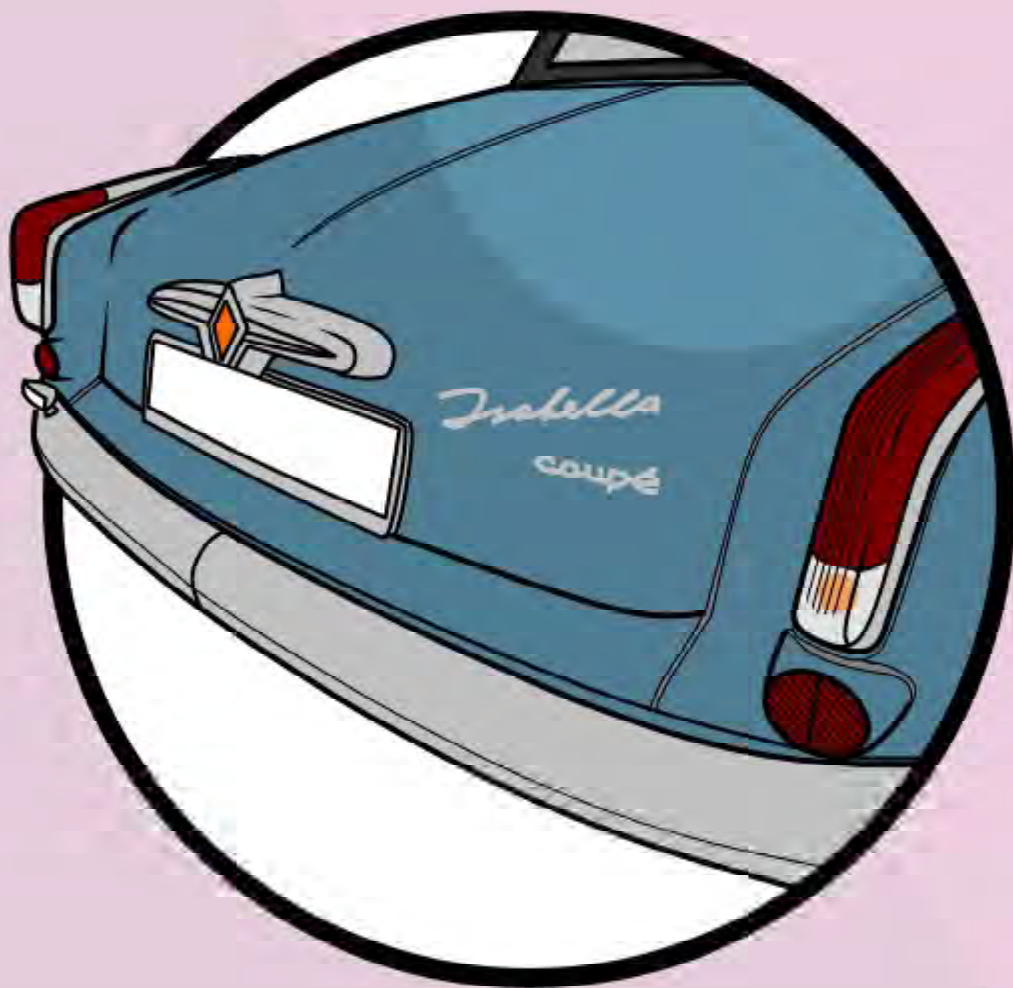

Chromteile 7000



03



04



14

Borgward 05

Isabella 06

Borgward 07

Coupe 08



15



16



17

Chromteile 7000

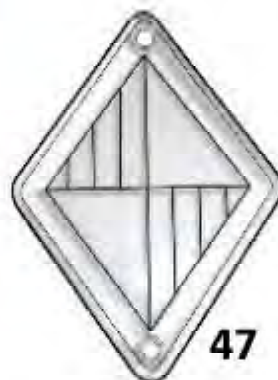

Art. Nr.	Artikelbezeichnung/Description	Menge	excl. Eur	Euro
7001				
7002	Blendring "Hella" ab 1958, nicht mehr lieferbar Outer ring head lamp			
7003	Radzierkappe, altes Emblem, Reproduktion 1 A verchromt Wheel cap, old sign, 1954 – till 1960	St.	100,84	120,00
7004	Wie vor jedoch unverchromt same like 7003 but unchromt	St.	24,36	29,00
7005	Typenzeichen Borgward für Limousine, montagefertig, Repr 1 A Type badge Borgward Sedan fender, ready for mounting, first Quality	St.	84,03	100,00
7006	Typenzeichen Isabella Messing verchromt Type badge Isabella plastic	St.	79,83	95,00
7007				
7008	Typenzeichen BORGWARD für Coupé Kotflügel, Repr 1 A Type badge BORGWARD fender coupé	St.	100,84	120,00
7009		St.		
7010		St.		
7011	Typenzeichen Coupé wie vor, montagefertig Type badge ready for mounting	St.	100,84	120,00
7012		St.		
7013	Buchstabensatz Motorhaube same like for, ready for mounting	St.	100,84	120,00
7014	Außenspiegel Coupé Mirror outside, left - coupé	St.	92,43	110,00
7015	Leuchtenkappe Limousine, 54 – 58, hinten, ohne Chromrahmen Lamp cap without blind frame	St.	33,61	40,00
7016	Leuchtenkappe Blinker unten, Limousine Lamp cap sedan	St.	25,21	30,00
7017	Handschuhkasten Coupé, Kunststoffnachfertigung Glove compartment - coupé	St.	42,02	50,00
7018	Luftkanal – Coupé, Kunststoffnachfertigung Air canal – coupé	St.	42,02	50,00
7019	Schwinge mit Türstück, rechts, innen matt verchromt, Messingrepro Moulding fender and door, RH	St.	252,10	300,00
7020	wie vor, jedoch linke Seite same like for, LH	St.	252,10	
7021				
7022				
7023				
7024	Stoßstangenhälfte, rechts oder links, montagefertig, 1 A Chrom Bumper half – RH or LH, reproduction, ready for mounting	St each	250,42	298,00
7025	wie vor, jedoch unverchromt same like for but without chrom	St. each	121,84	145,00

Art. Nr.	Artikelbezeichnung/Description	Menge	Excl. Euro	Euro
7026	Zierleiste Coupéschweller, Reproduktion, verchromt Moulding rocker plate, coupé, chrom	St.	100,84	120,00
7027	Zierleiste Limousinenschweller, wie vor Moulding rocker plate, sedan, chrom	St.	100,84	120,00
7028	Trittbrettleiste, R – Schweller, Edelstahlnachfertigung, Coupé Footboard, batten RH – sill, stainless steel	St.	100,00	119,00
7029	Trittbrettleiste, L – Schweller, wie vor, Coupé Footboard, batten LH – sill, stainless steel	St.	100,00	119,00
7030	Trittbrettleiste, R – Schweller, wie vor Limousine Footboard, batten RH – sill, sedan	St.	100,00	119,00
7031	Trittbrettleiste, L – Schweller, wie vor Limousine Footboard, batten LH sedan	St.	100,00	119,00
7032				
7033	Rosettensatz 3 tlg. alle Modelle nicht mehr lieferbar Escutcheon set 3 pieces, all models	Set		
7034				
7035				
7036				
7037				
7038	6 Kt.-Mutter M 10 DIN 934 Nut, hex. – rear bumper bracket to body	St.	0,84	1,00
7039	6 Kt.-Schraube M 10 x 28, DIN 931, Stoßstange an Winkel Bolt, hex. – bumper to bracket, 10 x 28 mm	St.	0,84	1,00
7040	wie vor, M 10 x 60 same but 10 x 60 mm	St.	0,84	1,00
7041	Fächerscheibe A 10,5 DIN 6798 Fan type washer – bumper lateral to fender	St.	0,22	0,25
7042	Scheibe 44 x 12 x 2,5 – Stoßstange an Gummiblock Washer – bumper lateral to fender	St.	0,73	0,85
7043	Hupendrucker, unbemahlt Horn button, without collar	St.	25,21	30,00
7044	Leuchtenkappe – Blinker hinten, ab Bj. 9/58 Lamp cap – blinker-parking lamp	St.	57,98	69,00
7045	Zierleiste Frontscheibe unten, Lim. und Coupé, muß angepasst werden Moulding, windscreen bottom	St.	42,01	50,00
7046	Gummipuffer - Stoßstange an Kotflügel Rubber buffer – bumper lateral to fender	St.	12,61	15,00
7047	Plakette – Kennzeichenleuchte, ohne Verspiegelung, zum ausmalen Badge – license plate lamp, without collar	St.	11,64	13,50
7048	wie vor, goldfarbig und chromfarbig verspiegelt same like 7047, but ready to mounting	St.	29,41	35,00
7049	Plattenschraube – Zierleiste Motorhaube Plate screw – moulding motor hood	St.	1,08	1,25
7050	Leuchtenkappe Blinker vorne oben – gelb Lamp cap – lenses – blinker front top, clear for the USA	St.	37,81	45,00

*Scheiben
& Co.*

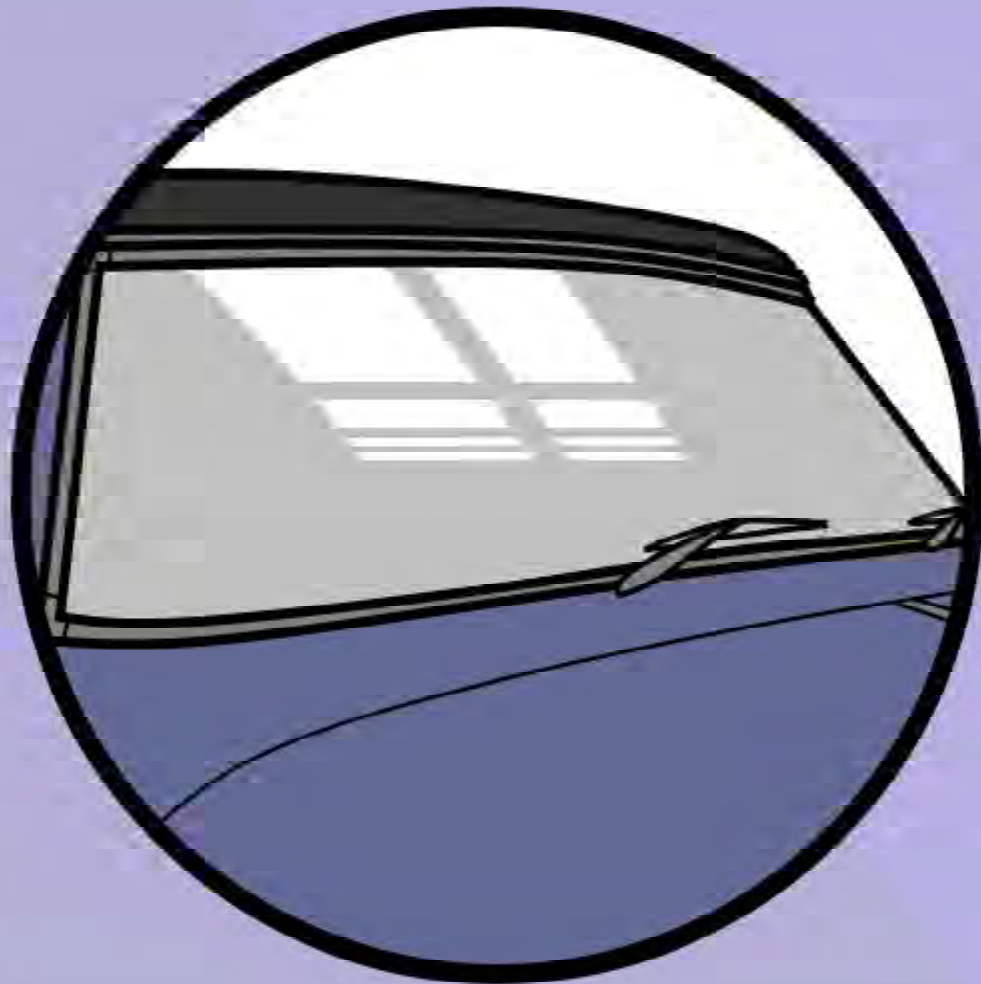

Glas und Zubehör
8000



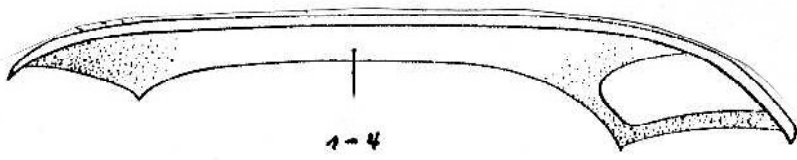

1-4

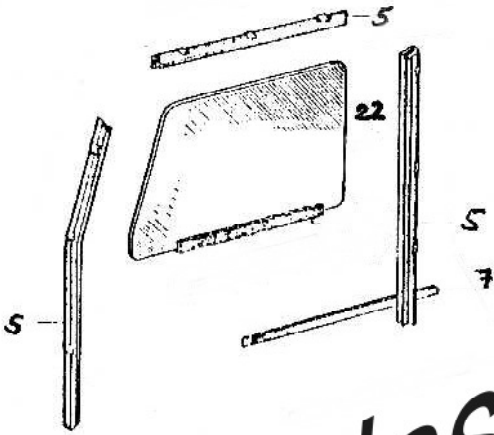

Glas und Zubehör



6

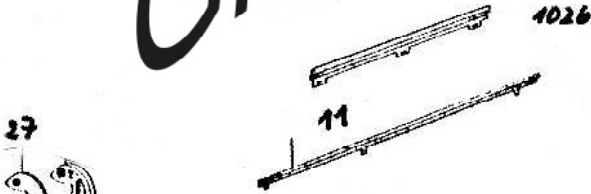

1026

11

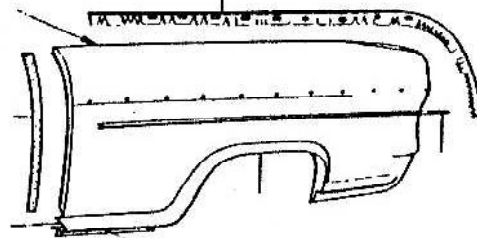

9-10



27



18

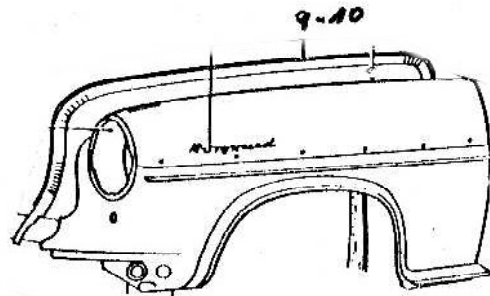
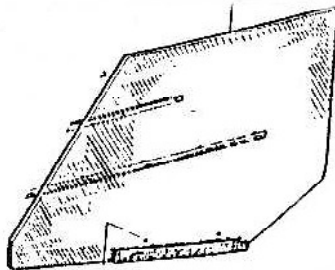

9-10

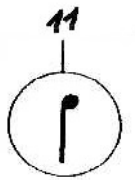

11

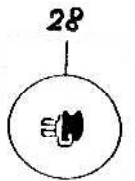

28

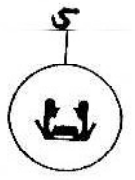

5

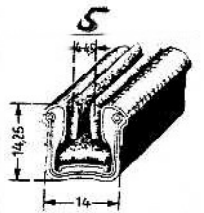

5



6

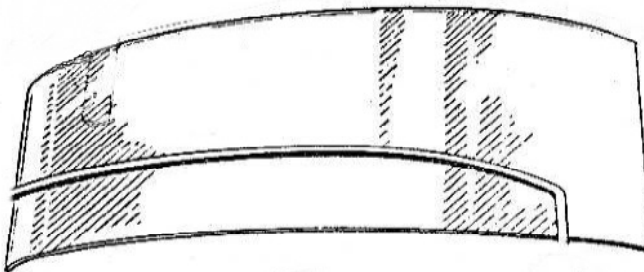

24/25

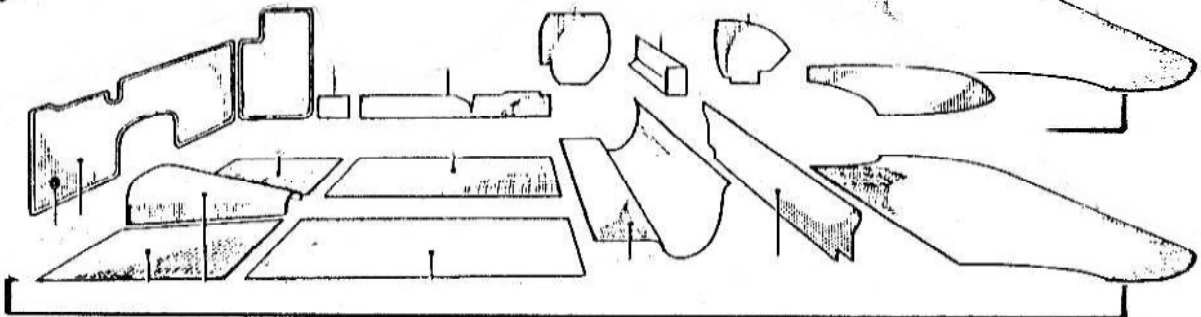

12-15

Art. Nr.	Artikelbezeichnung/Description	Menge	excl Euro	Euro
8003	Himmeltuch einbaufertig, Coupé – Kunststoff gelocht Headlining finished – plastic	St.	184,87	220,00
8005	Türscheibenbürstenmaterial, U – Profil verbesserte Ausführung Flexible window guide rail	Meter	11,77	14,00
8006	Fensterschacht – Samtleiste, Coupé Window compartment sealing – coupé	St.	8,40	10,00
8007	Fensterschacht – Samtleiste, Limousine Window compartment sealing – sedan	St.	7,98	9,50
8008				
8009	Kotflügel – Kederband 4mm, schwarz Beading fender 4mm, black	Meter	4,62	5,50
8010	Kotflügel – Kederband 4mm, silber Beading fender 4mm, silver	Meter	4,62	5,50
8011	Kederband 2,5mm, schwarz – Schweller/Kotflügel Beading 2,5mm, schwarz	Meter	3,02	3,50
8012				
8013				
8014				
8015				
8016				
8017	Dämmmaterial wie Armaflex, 19mm, das Beste überhaupt, wir testeten dieses Material in mehreren Fahrzeugen, Testsieger! Auch in 13, 16, 25 mm lieferbar	qm	25,00	29,75
8018	Armlehnengehäuse Nachfertigung Arm rest housing, shockproof	St.	35,29	42,00
8019	Messingdraht für in das Kederband Brass wire for into the beading 8010/11	St.		n. l.
8020				
8021	Türscheibe Isabella Coupé Cabriolet rechts oder links z. Zeit nicht lieferbar	St.	294,12	350,00
8022	Türscheibe Limousine ab 9/58 Window pane – door window from model 9/58 sedan	St.	94,82	110,00
8023	Türscheibe Isabella Coupé rechts oder links Window pane for Isabella Coupé r or leftside	St.	294,12	350,00
8024	Frontscheibe – Limousine, Verbundglas Windscreen – sedan	St.		
8025	Frontscheibe – Coupé, Verbundglas Windscreen – coupé	St.	273,00	325,00
8026	Türscheibe – Limousinencabriolet, ab 9/58 Window pane – sedan convertible	St.	142,24	165,00
8027	Schlossfalle Coupé – B-Säule, r oder l Striker plate – side door, coupé LH or RH	St.	74,79	
8028	Befestiger Fensterschacht – Samtleiste clip – window compartment sealing	St.	0,63	0,75
8029				
8030	Kunstleder – Sitzmaterial, verschiedene Farben Leatherette covermaterial – different colores	qm	16,81	20,00

Hinter- achse



Hinterachse 9000



Art. Nr.	Artikelbezeichnung/Description	Menge	excl. Euro	Euro
9001	Hinterachsmanschette Protective collar – rear axle tube	Stück	21,00	25,00
9002	Querträger Hinterachse, tauchlackiert Cross member – rear axle	St.	57,98	69,00
9003	Ringkegellager – Antriebskegelrad Roller bearing – differential pinion support	St.	38,79	45,00
9004	Ringrillennlager – 6205 Antriebskegelrad Roller bearing	St.	13,86	16,50
9005	Wellendichtring – Kugellagerbüchse an Achsrohr Oil seal ball bearing housing to axle type	St.	11,77	14,00
9006	Ring Ringrillennlager 6306-C3 oder 6207 C4 ab Wagen-Nr. Rear axle shaft bearing from Ser. no. Lim + TS 734147 Combi 230843 Coupe 346002	St.	24,37	29,00
9007	O-Ring Kugellagerbüchse an Achsrohr Packing ring – ball bearing housing to rear axle	St.	3,02	3,50
9008	Splint 4 x 35 Splint pin	St.	0,23	0,26
9009	Schubstrebe Hinterachse schwarz getaucht Radius arm	St.	49,37	59,00
9010	Wellendichtring Differentialhals 305210 Oil seal	St.	11,77	14,00
9011	Gummipuffer – Querträger Hinterachse Rubber buffer – cross member to rear axle	St.	11,35	13,50
9012	Gummipuffer – Querträger Hinterachse Rubber buffer – cross member to rear axle	St.	7,56	9,00
9013	Teleskopstoßdämpfer Hinterachse, F&S Shock absorber – rear axle	St.	63,03	75,00
9014	Gummiring Lagerschale – Schubstrebe Rubber ring – bearing retainer	St.	15,13	18,00
9015	Kugelbundmutter – Radmutter, Schlüsselweite 19mm Collared nut – wheel stud	St.	2,59	3,00
9016	Kreuzgelenk in Kardanwelle, Achtung, zwei verschiedene Größen je nach Welle 1. und 2. Ausführung	St.	84,03	100,00
9017	Deckel für Schubstrebenaufnahme	St.	49,58	59,00
9018	Spannband für Achsmanschette V2A	St.	2,52	3,00
9019	Einschweißteil an Karosserie, Schubstrebenaufnahme	St.	49,58	59,00

Vorder- achse

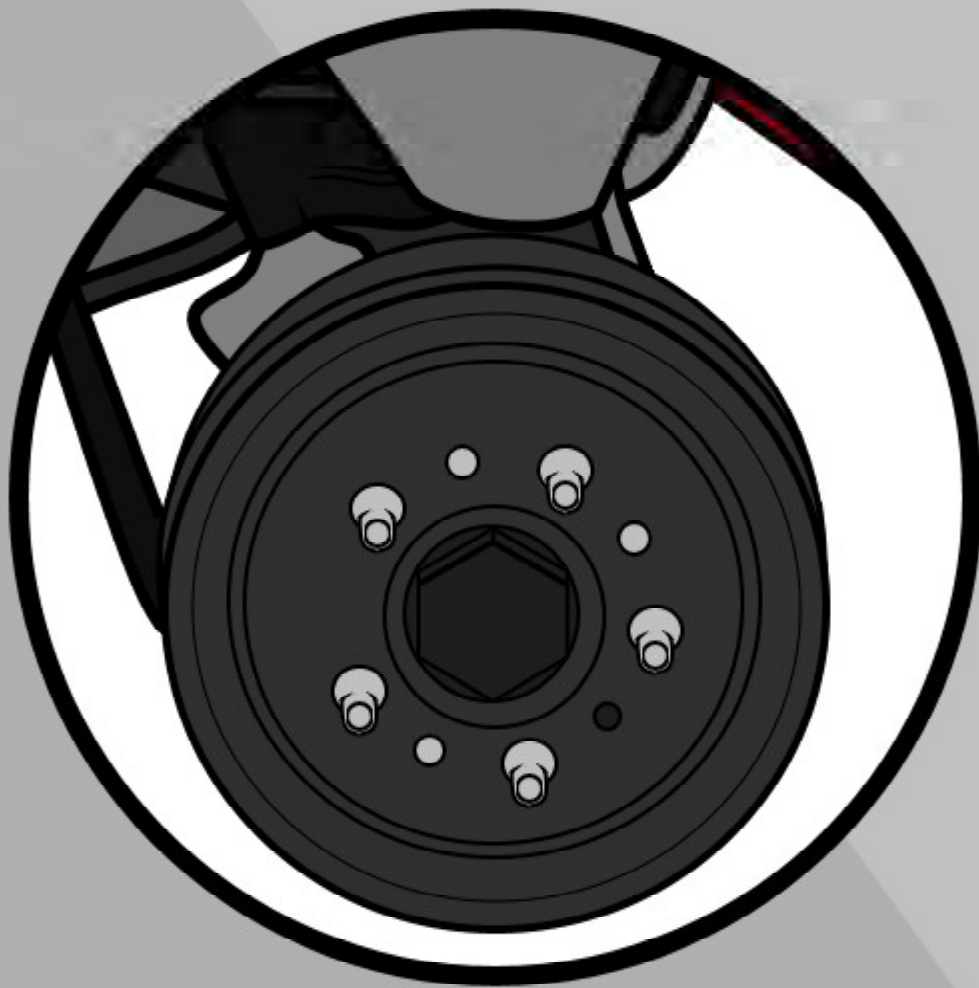

Vorderachse
9100



Art. Nr.	Artikelbezeichnung/Description	Menge	excl..Euro	Euro
9101	Ringrillenlager Vorderachse 6306, Bj. 54 – 8/60 Annular grooved ball bearing – stub axle rear	St.	22,69	27,00
9102	Ringrillenlager VA 6304, Bj. 54 – 8/60 Annular groove ball bearing – stub axle front	St.	15,13	18,00
9103	Radialdichtring B 1 45x62x10 – Achsschenkel Radial sealing ring – stub axle	St.	15,97	19,00
9104	Radlagersatz mit Radialdichtring – Bj. 60 – 62 Ball bearing – set, stub axle front and rear, with sealing	Set	42,02	50,00
9105	Radialdichtring für BJ 60 - 62 einzeln Radial sealing ring	St.	9,24	11,00
9106	Traggelenk unten Universal joint bearing to stub axle down	St.	82,35	98,00
9107	Führungsgelenk oberer 3-eckslenker	St.	74,78	89,00
9108	Lagermutter unten - auf Welle nicht mehr einzeln lieferbar Bushing – bar bottom	St.		
9109	Gummipuffer - Lenkerhebel oben Rubber buffer – wishbone, bottom	St.	8,40	10,00
9110	Gummipuffer – Lenkerhebel unten Rubber buffer – wishbone, below	St.	10,92	13,00
9111	Gummipuffer – Vorderachse an Karosserie Rubber buffer – front axle to body	St.	15,54	18,50
9112	Teleskopstoßdämpfer – Boge, Teleskopic shock absorber	St.	79,83	95,00
9113	Motorlagerbock an Fahrschemel, original Nachfertigung Rubber buffer, front - motor	St.	32,77	39,00
9114	Lagerwelle oben mit Muttern, Neuteile	St.	222,69	265,00
9115	Lagerwelle unten mit Muttern, Neuteile	St.	231,09	275,00

Vorderachse 9200



Vorderachse



Art. Nr.	Artikelbezeichnung/Description	Menge	excl. Euro	Euro
9201	Spurstange mitte, wieder lieferbar Tie rod – center	St.	105,04	125,00
9202	Spurstange außen, kpl. Tie rod – outer, complet	St.	42,02	49,00
9203				
9204				
9205	Stabilisatorschraube – Lenkerhebel unten, kpl., V2a Rohr Bolt complete – stabilizer to lower drop arm	St.	21,00	25,00
9206	Gummiring – Stabilisator Rubber buffer – stabilizer to lower drop arm	St.	1,68	2,00
9207	Gummilager – Stabilisator an Karosserie Rubber cushion – stabilizer	St.	10,08	12,00
9208				
9209	Nadellager Umlenkhebel	St.	10,08	12,00
9210				
9211	Dichtring Lenkgetriebe, vorne klein 15x21x5/7B1 SL Sealing ring – steering gearbox	St.	8,40	10,00
9212	Dichtring Lenkgetriebe, unten – Lenkstockhebel 25x36x7 BA Sealing ring, bolt	St.	11,76	14,00
9213	Dichtring Lenkgetriebe, hinten – Hardyscheibe 20x32x7 BA Sealing ring	St.	8,40	10,00
9214	Dichtring Schaltgetriebehals BA 33x52x10 Sealing ring – gearbox	St.	11,77	14,00
9218	Ringrillenger 6306 N “C3” Ball bearing	St.	24,37	29,00
9219	Ringrillenger 6205 „C2“ Ball bearing	St.	21,01	25,00
9220	Tachometerwelle – Coupé Bj. 57 – 61 Speedometeraxle – drive shaft	St.	57,98	69,00
9221				
9222				
9223	Faltenbalg – Motorhaubenverriegelung Bellow – pull rod	St.	15,97	19,00
9224	Gelenkscheibe, Lenksäule – Lenkgetriebe Joint disk	St.	15,13	18,00
9225	Gummipuffer - Maske / Motorhaube Rubber buffer – grille	St.	2,52	3,00
9226	Kugellagerträger – Umlenkhebel	St.	n.l.	n.l.
9227	Lager Schaltgetriebe 6305 Ball bearing Gearbox	St.	16,81	20,00
9228	Lenkungsämpfer Isabella, nicht mehr lieferbar Shock absorber – steering, old against new	St.	75,63	90,00

Kühlung



Kühlung 10000



Kühlung 10000

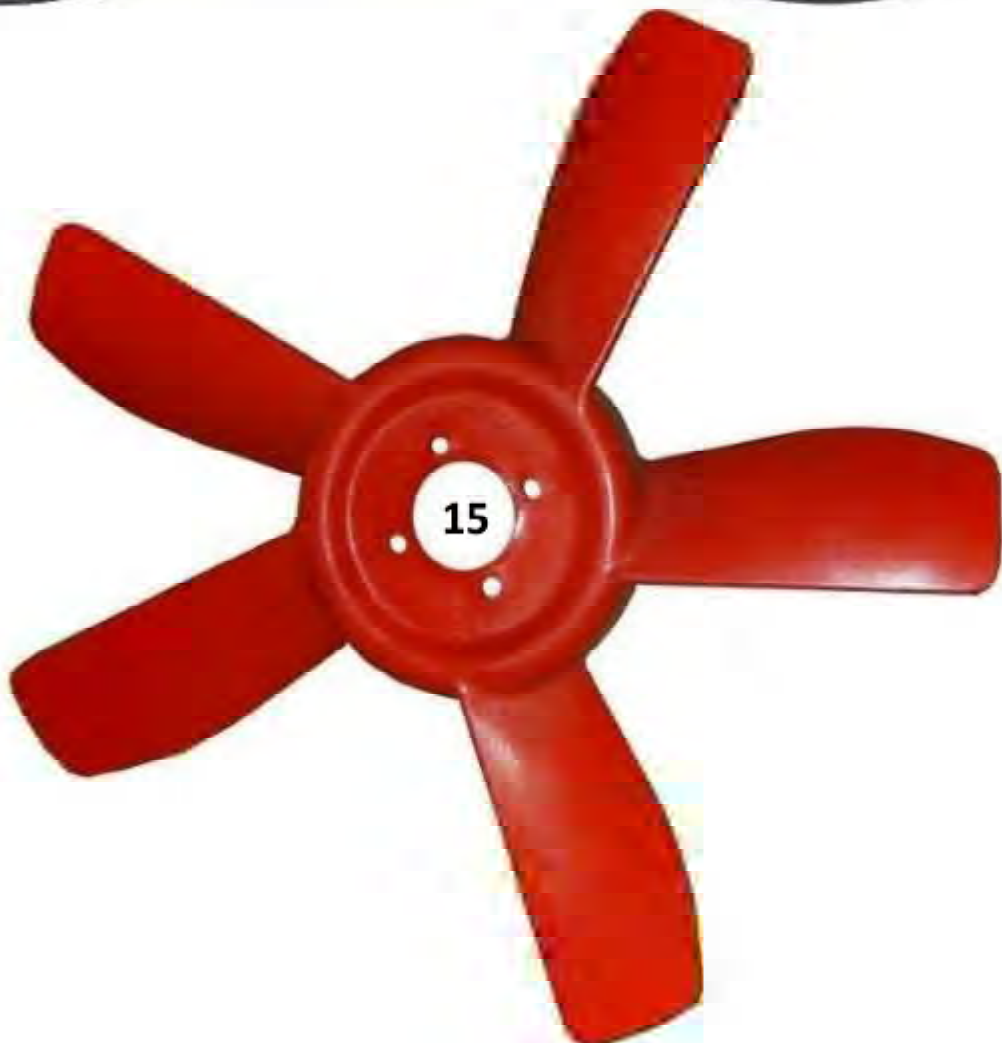

Art. Nr.	Artikelbezeichnung/Description	Menge	excl. Eur	Euro
10001	Wasserpumpendichtring Schleifring Slide ring sealing	St.	29,41	35,00
10002	Wasserpumpenrepsatz komplet mit allen Innereien	Set	116,80	139,00
10003				
10004	Simmering statt Filzring Sealing ring	St.	10,92	13,00
10005	Dichtung – Deckel und Motorbohrung, Satz 2 Stück Gasket cover to waterpump body, set 2 piece	St.	8,40	10,00
10006	Thermostateinsatz 79 Grad Thermostat insert	St.	25,21	30,00
10007	Deckel für Thermostatgehäuse Cover to thermostat body	St.	21,01	25,00
10008	Dichtung – Deckel an Gehäuse Gasket – cover to thermostat body	St.	2,10	2,50
10009	Heizungs- und Kühlschlauchset, mit Schellen, 8 Schläuche, ohne 10014 Rubber hose – air conditioning system	Set	42,02	50,00
10010	Kugellager Wapu Ball bearing – water pump	St.	12,60	15,00
10011				
10012	Dichtring Steigrohr Sealing ring – connector	St.	2,10	2,50
10013	Kühlerverschluss, mit Druckknopf Radiator screw cap – with presser valve	St.	15,97	19,00
10014	Kühlerschlauch zum Thermostatgehäuse Rubber elbow – radiator to thermostatbox	St.	16,81	20,00
10015	Lüfterflügel Kunststoff, 5 Flügel Fan, plastic, better as original, 5 wings	St.	57,98	69,00
10016	Sicherungsring, 42 x 1,75 Circlip	St.	1,12	1,30
10017	Keilriemen Isabella Narrow V – Belt	St.	10,92	13,00
10018	Dichtung - Thermostat an Zylinderkopf Gasket – thermostat to cylinder head	St.	2,10	2,50

Besfestiger Zierschrauben, Rosetten

04 | R



04 | V



05 | V



05 | R



06



07



08



08



09



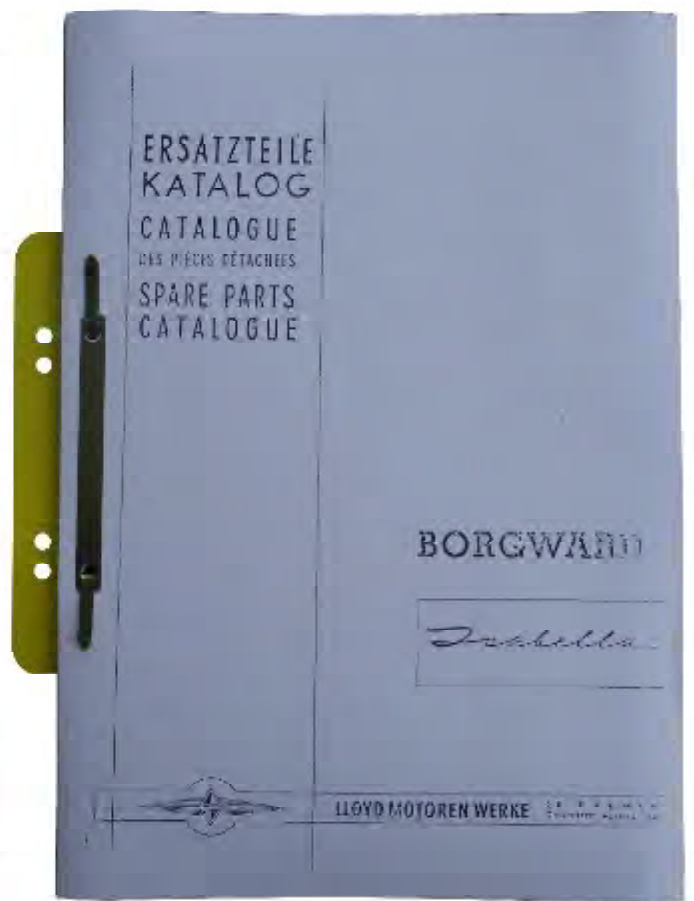

Art. Nr.	Artikelbezeichnung/Description	Menge	excl. Euro	Euro
11001	V2A Liko – Schraube für Coupéholzleisten 3,9 x 38mm	St.	0,39	0,45
11002	V2A Liko – Schraube für Innenausstattung 3,9 x 32mm	St.	0,39	0,45
11003	V2A Liko – Schraube für Innenausstattung 3,9 x 19mm	St.	0,30	0,35
11004	Rosette für Coupéholz	St.	0,26	0,30
11005	Rosette für Innenausstattung	St.	0,86	1,00
11006	Befestiger für Schriftzüge und Buchstaben	St.	0,86	1,00
11007	V2A Stoßstangenverbindungsschrauben	St.	1,12	1,30
11008	Chromschraube für Blinkerkappen	St.	0,48	0,55
11009	Schraube – Türscharniere	St.	1,73	2,00
12001	Reparaturanleitung / KD –Rundschreiben, über 300 Seiten – Kopie Manual – repair – instruktion, german language only, with pictures	St.	34,48	40,00
12002	ET-Liste mit allen Nummern und Bildern, über 500 Seiten Original – repaire-part list, more then 500 pages	St.	56,90	66,00
12003	Zusammenbauplan / Explosionszeichnungen Manual description to fittund, picture only	St.	12,61	15,00
12004	Betriebsanleitung ISABELLA, Kopie Manual description	St.	12,61	15,00

Nachfolgend einige Bilder von meinem Borgwardfund in Denver-Colorado USA

Im Jahre 1991 bereiste ich wieder die USA und bekam von einem Geschäftsfreund das Angebot, die in Denver stehenden 29 Borgward zu erwerben. Was sich Anfangs so gut anhörte, erwies sich schnell als Abenteuer.

Wer sollte die Fahrzeuge transportfähig machen? wer organisiert den Transport der Fahrzeuge sowie den Container? was kostet das alles?

Ich bekam eine Option für die Dauer von sechs Monaten. Dann mußte die Entscheidung fallen. Ja oder nein, daß war hier die Frage.

Im April 1992 war es dann soweit. Ich flog mit zwei Mitarbeitern nach Los Angeles, mietete dort einen Leihwagen und ab ging es nach Denver. Voller Tatendrang ging es an die Knochenarbeit. Zum Glück lernten wir einen Amerikaner kennen, der Mitleid mit den verrückten Deutschen hatte. Carol versorgte uns nach einem Tag der stillen Beobachtung mit seinem Werkzeug, elektrischem Strom und seinem Gabelstapler. Wenn das nicht so gekommen wäre, hatten wir nicht alles was mir wichtig war mit nach Hause nehmen können.

Sehen Sie selbst, wie es zugeht in einem fremden Land und zehntausend Kilometer away from Home. Das wußte schon Freddy vor 25 Jahren zu besingen.





USA 1992, DENVER-COLORADO

29 Borgward warten auf die große Reise



Es kommt Bewegung in die "Sache"



"Schlüsselübergabe"



"Zigarettenübergabe" an unseren amerikanischen Freund Karol-Klee Johns



So sieht es von Oben aus, rollbar und in Warteposition



Wehe einer nimmt was weg

Container im Hintergrund-voll mit Borgward-Ersatzteilen



Es ist angerichtet, Mittagessen in angenehmer Atmosphäre



Auch die Eichhörchen denken ans Essen, Borgward voller Tannenzapfen

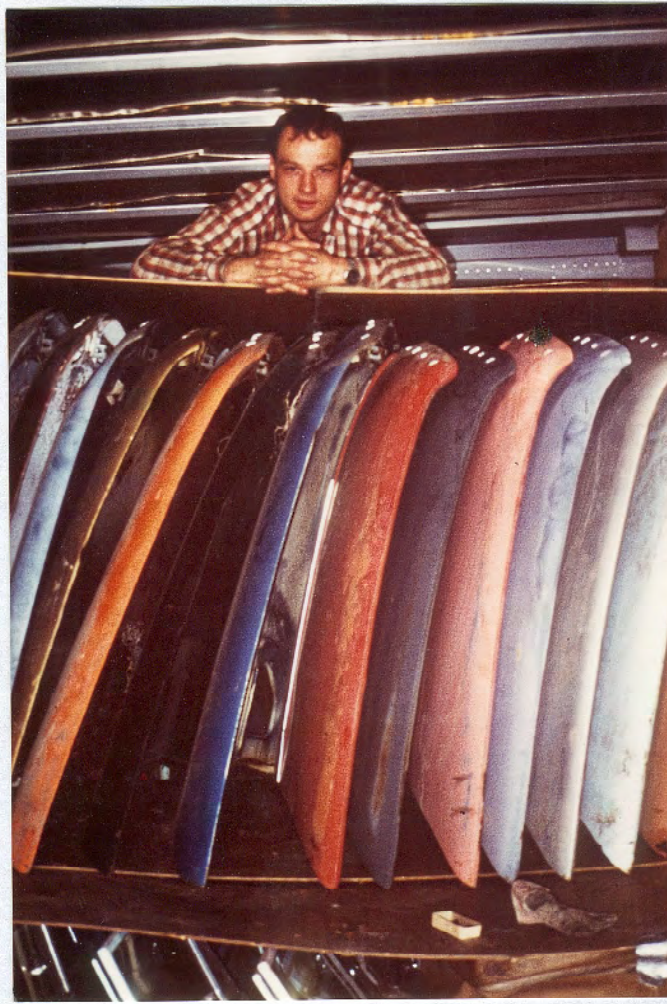

Container in 3 Etagen gepackt; denn wie man sich bettet...



Coupé auf der Gabel, wer nicht rollt wird getragen



On the way-fahr los, wir wollen nach Hause



Halt, da fehlen noch zwei Kabrios



Genug Getriebe für die nächsten Jahre



Numberplates-Trophäen für zu Hause



12 Kombis geschlachtet, da bricht einem das Herz.
Doch die Transport- und Nebenkosten sind höher als der Marktwert
in Deutschland.



Nanu, alles weg? Und das nur zehn Tage nach unserer Ankunft!